

Robin Classic

Clean shape. Clean water.



Robin Classic OPERATING MANUAL

TABLE OF CONTENTS

1. INTRODUCTION.....	4
2. PRESENTATION.....	5
3. SAFETY INSTRUCTIONS.....	6
4. FUNCTIONING.....	7
5. INSTALLATION.....	10
6. PROGRAMMING.....	13
7. COMMISSIONING.....	19
8. TROUBLESHOOTING.....	22

1. INTRODUCTION

We would like to thank you for acquiring our Robin water softener. You have made an excellent choice that will allow you to benefit from the highest quality of water in the future.

The Robin is delivered in a cardboard box together with a by-pass. Please check the softener carefully, in the presence of the delivery man, to ensure you that it was not damaged during transport.

Before starting up your softener, please read this manual carefully. Proper installation guarantees a long service life and high performance of your water softener.

The packaging can be fully recycled, please dispose of it in a suitable place.

Join our mission.
Make water count.

2. PRESENTATION

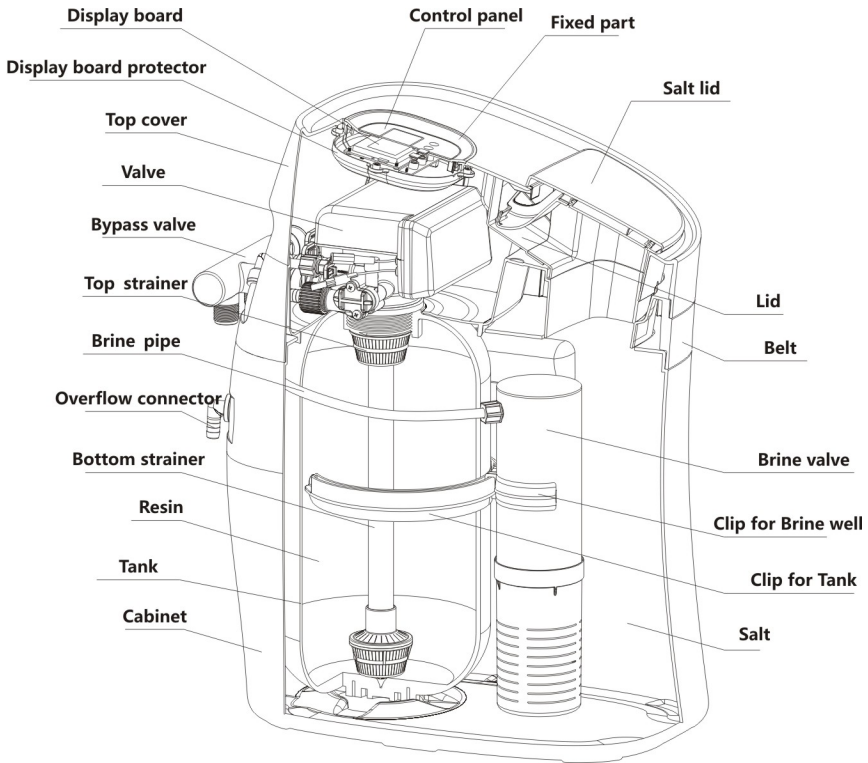

3. SAFETY INSTRUCTIONS

The installer/user should read the manual in full. The installer must ensure that the manual is available to the user in a legible form. The installer must ensure that all safety measures are followed and maintained.

The following safety and installation instructions are applicable:

- Never install or operate damaged products.
- Only use unaltered and compatible original parts.
- If the equipment is opened improperly, is wrongly installed, commissioned or operated, there is risk of physical injury and material damage.
- The equipment contains parts that can be swallowed.

TRANSPORT

The Robin softener is delivered in a box. Please inspect carefully your device to be sure it has not been damaged during transportation.

INSTALLATION

Follow all instructions for installation. See chapter 4 'Installation softener'.

PROPER USE

The equipment is to be used on city water. The user is solely responsible for any damage incurred by improper use of the equipment.

EXCLUSION OF LIABILITY

The manufacturer accepts no liability for personal injury or material damage incurred due to misuse or errors caused by improper installation, commissioning or operation.

The safe and fault-free use and the operational safety of the equipment is only guaranteed with proper use according to the specifications of this operating manual.

Join our mission.
Make water count.

4. FUNCTIONING

4.1. GENERAL FUNCTIONING OF A WATER SOFTENER

A water softener provides softened water by removing ions such as Calcium and Magnesium from the incoming water. The incoming water is sent to the valve that directs the water over a vessel filled with special softener resins. These resins will exchange the “hard” Ca- and Mg-ions present in the water for soft “Na”-ions. The softened water coming out of the vessel is then sent via the valve to the different tap-points in the house.

The resins have a certain capacity to remove hard ions from the water. The harder the water or the higher the water consumption, the faster the resins will be exhausted. As the water hardness is known and fixed, the resin bed will be exhausted after a certain amount of water. At this moment, the resins have to be regenerated in order to bring them back to their initial capacity. This regeneration is done by bringing them in contact with brine (dissolved salt (Na-ions)). In order to be able to create the brine, the softener-cabinet is to be filled with salt-tablets. After brining, the resin bed has to be rinsed

and backwashed so that there is no salty taste and the resin bed is in perfect condition to capture again incoming hardness ions (Ca- and Mg-ions).

The heart of the softener is the valve, equipped with a controller that manages the softener in a fully automated way. Water consumption is measured and the valve will trigger at the appropriate moment a regeneration. A regeneration consists out of 4 cycles:

- **Backwash:** water is sent over the resin bed in the opposite way in order to remove possible impurities on top of the bed and to unpack the resin bed.
- **Brining and slow-rinse:** brine is being sent over the resin bed.
- **Refill:** water is sent to the part of the cabinet where the salt is located. This water will dissolve a part of the salt so that the necessary brine will be available to perform the next regeneration.
- **Fast rinse:** the last traces of brine are removed and the bed is packed again.

4.2. FUNCTIONING

The Robin Classic has the following characteristics:

	Mini	Maxi
Resin volume	12L	26L
Control System	F69PHY	F69PHY
Regeneration type	Upflow / Downflow	Upflow / Downflow
Nominal flow	0.8 m ³ /h	1.0 m ³ /h
Peak flow	1.2 m ³ /h	1.2 m ³ /h
Exchange capacity - XLB*	0.35 kg CaCO ₃	1.20 kg CaCO ₃
Water extraction possible during regeneration	Yes, hard water	Yes, hard water
Working pressure**	2 - 6 bar	2 - 6 bar
Feedwater temperature range	5 - 45 °C	5 - 45 °C
Connected power supply	220V/50Hz	220V/50Hz
Diameter inlet & outlet	3/4"	3/4"
Diameter drain	1/2"	1/2"
Dimensions (H x W x D)	653 x 320 x 503	1112 x 320 x 555

(*) XLB = Extra low brining

(**) It is necessary to put a pressure reducer in case the incoming pressure is higher than 6 bar or is unstable ("Water hammer")

Join our mission.
Make water count.

- The Robin softener keeps track of the water consumption via an integrated water meter. The amount of water that can be softened depends on the water hardness of the incoming water and is programmed when commissioning the system.
- When the resin bed is exhausted, the Robin softener will perform a regeneration. This regeneration is programmed by default at 2 a. m. because there is no softened water available during regeneration. If necessary, the regeneration hour can be modified.
- The Robin softener will optimise the moment of regeneration based on the real water consumption of the user.
- The Robin softener disposes of a large LED screen where the functioning of the softener can be monitored and parameters can be set or changed.
- Most of the parameters of the Robin softener are preprogrammed in the factory so that only a few user-specific parameters have to be set when commissioning the unit.
- Parameters are stored in the memory and will not be lost due to power outage.
- The Robin softener allows to configure the outgoing hardness by turning the hardness screw.
- The Robin softener allows to trigger a manual regeneration for special cases where this could be needed.

5. INSTALLATION

5.1. PREPARATION OF THE INSTALLATION

Location

The device is only to be used for interior operation. Install your softener on a flat, firm and clean surface. The unit must be close to a drain line to allow an easy connection. Check if there is an electrical earth grounded plug to power the unit. It is essential to foresee sufficient space for installation, commissioning and easy maintenance. It is also important to ensure good access for filling salt.

Pressure

A minimum incoming pressure of 2 bar is needed to allow the valve to perform a proper regeneration.

Always use a pressure reducer upstream of your installation to ensure a regular pressure during the day and to withstand water hammer during the night.

Power connection

Be sure that the power cannot be switched off accidentally by a wall switch.

If the power cable is damaged, please

ask a skilled electrician to change it.

When the unit is disconnected from the electrical network for a number of days, do not forget to reprogram the clock.

When the unit stays disconnected from the electrical network for a long period of time, please verify if all parameters are still set at the correct values.

Plumbing

The plumbing must be in good state. In case of doubt, please change it.

All plumbing for the water inlet, distribution and drain line should be done correctly and in accordance with the legislation in force at the time of the installation.

Possible soldering should be done before installing the softener. Failing to do so can generate irreversible damages. For any operation, shut down water inlet, unplug your softener and open faucets at the top and at the bottom of your house to drain your installation.

Join our mission.

Make water count.

The connection to the softener must be done using flexible hoses.

The connection to the drain should be done in accordance with legislation. Often an airgap is needed.

In order to adequately compensate the tank elongation the flexible tubes must be installed horizontally. If the flexible piping connection is installed in vertical position, instead of compensating the elongation, it will create additional stresses on the valve & tank assembly.



Filter

A pre-filter is needed upstream of the softener in order to protect the valve from impurities present in the water that might cause damage to the valve or its seals.

Water temperature

The temperature of water should not exceed 45 °C and the installation should not be subjected to freezing conditions (risk of very serious damage).

Do not use the softener on hot water!

Salt

Only use salt tablets for water softening applications (purity should be at least 99.5%). Other types of salt, for example, finely granulated are not permitted.

PHYSICAL INSTALLATION

After unpacking the system, please put the power supply, bypass valve and any other accessories apart. When moving the system, pay attention not to hold or move the softener by hoses, valves or other parts not suited for that purpose. In cold weather, it is recommended

that the Robin is brought up to ambient temperature before proceeding with the installation. The Robin must be positioned so that it is protected from freezing temperatures. Do not install the unit where it is exposed to direct sunlight or high temperatures (45 °C max).

Installation of the bypass on the softener:

- The installation of a bypass allows you to bypass the water softener when required (maintenance, need for unsoftened water, . . .).
- When the handle on the bypass is pulled out, the incoming water flows through the water softener. When the handle on the bypass is pushed in, the water flows directly to your tap-points without being softened.
- Use the clips to fix the bypass to the income and the outlet of the valve.
- The drain connection on the valve must be connected to the drain.
- The overflow connection on the cabinet has to be connected (seperately from the drain connection on the valve) to a drain that is situated below the softener as possible water coming out is unpressurised.

WATER GOES INTO THE VALVE

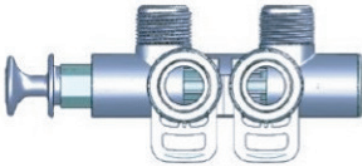

NO WATER GOES INTO THE VALVE



Join our mission.
Make water count.

6. PROGRAMMING

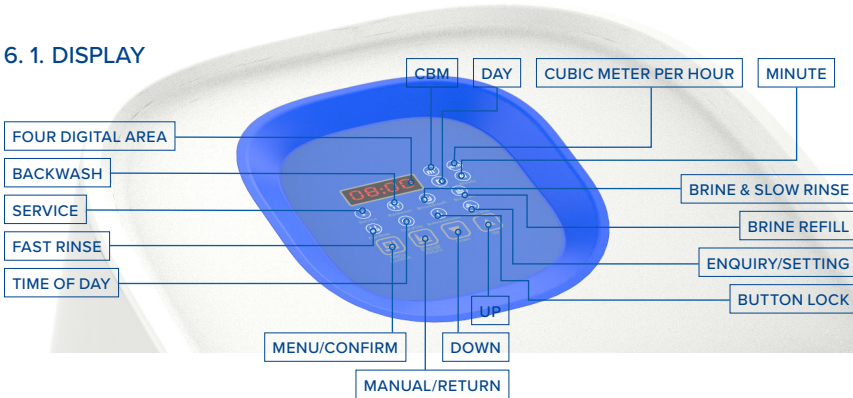

6.1. DISPLAY



Time of day indicator



When the indicator light  is on, the time of day is displayed.



Button lock indicator

When the indicator light  is on, all buttons are locked. If there is no operation during one minute, the  will light up and lock the buttons.





Press and hold  and  for 5 seconds until the  lights off.





Program mode indicator

When the indicator light  is on, you can enter the display mode. Use  and  to view all values.

When the indicator light  flashes, you can enter program set mode. Press  and  to adjust values.



Menu/Confirm button



Press ,  lights on, enter the program display mode and use  and  to view all values.

In program display mode press ,  flashes, enter program set mode, press  and  to adjust values.

Press  after the values are set. The beep sound means that all settings were successfully saved and you return to the program display mode.



Manual/Return button



Press  in any status, the softener will proceed to the next step. For example, if your press  during service, the softeners will start to regenerate. When pressing  during backwash, the unit will end backwash and go to brine & slow rinse at once.



Press  in program display mode and it will return to service. Press  in program set mode and it will return to program display mode.

Press  while adjusting a value, the display will return to program display mode without saving the adjusted value.

Down and Up &

In program display mode, press  and  to view all values.

In program set mode, press  and  to adjust values.

Press and hold  and  for 5 seconds to lift the button lock status.

6.1.1 Display during service

- When the softener is in use, different screens appear periodically on the display. The type of screens that appear depends whether the softener is in service or performing a regeneration. The actual time is always one of the parameters that is shown.

- The softener is in service**

The following screens will appear periodically:

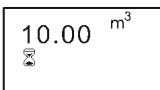

Figure A

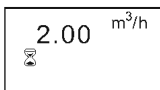

Figure B

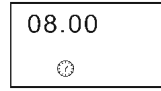

Figure C

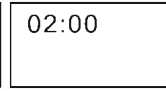

Figure D

6.1.2 Display during regeneration

- During regeneration, you will see the current regeneration cycle on the screen.
- Regeneration cycle 1: Softener is in the backwash cycle. You can see water flowing at high speed to the drain.

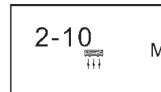

Figure E

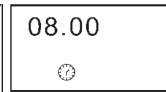

Figure C

- Regeneration cycle 2: Brine and slow rinse. You can see water flowing at moderate speed to the drain.

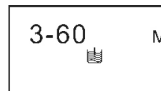

Figure F

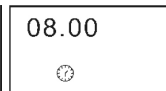

Figure C

- Regeneration cycle 3: Brine Refill. You can see water flowing at moderate speed in the softener cabinet.

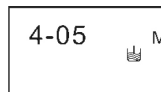

Figure G

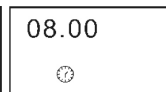

Figure C

Join our mission.

Make water count.

- Regeneration cycle 4: Fast rinse. You can see water flowing at high speed to the drain.

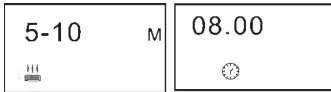



Figure H

Figure C

In each status, every display appears for 15 seconds.

6.1.3 Resetting the clock

When the  flashes continuously, such as “12:12”, the device has been without power for at least three days. The clock must be reset.



6.1.4 The softener is in error-mode

When the system malfunctions, the display will show an error code such as “-E1-”.













6.2. BASIC PROGRAMMING

Caution: The programming has to be done only by the installer for the setting of the valve parameters. The modification of one of these parameters could prevent the good functioning of the device.







6.2.1 Parameters to be programmed by the user: setting of the clock

Press and hold both  and  for 5 seconds to unlock the buttons.











- Time of Day
When the time of day “12:12” flashes continuously, you need to reset the clock.

1. Press  to enter the program display mode, both  and  light up, “:” flashes.
2. Press both  &  and the hour value flashes, use  &  to adjust the hour value.
3. Press  again, both  and minute value flash, use  &  to adjust the minute value.
4. Press  and hear the beep sound, the values have been adjusted, press .







6.2.2 Parameters to be programmed during commissioning

- Unit Mode
 1. In unit mode display status, press  and enter the program set mode,  and the value 01 start flashing.
 2. Press  &  and choose m3 / L / gal.
 3. Press  and finish adjustment, press  to go back.



- Regeneration time





1. In regeneration time display status, the display shows 02:00. Press  and enter into program set mode.  and the value 02 start flashing.
2. Press  &  to adjust the hour value.
3. Press  again,  and the value 00 start flashing, press  &  to adjust the minutes value.
4. Press  and you will hear a beeping sound, press  to go back.

- Control mode

1. In control mode display status, press  and enter into the program set mode,  and the value 01 start flashing.
2. Press  &  set the value to A-01 (Meter delayed regeneration).
3. Press  and hear a beeping sound, press  to go back.

- Water treatment capacity

1. In water treatment capacity display status, you will see  and 10:00. Press  and enter into program set mode.  and 10.00 flashes.

2. Press  &  to adjust the water treatment capacity value (m3).
3. Press  and you will hear a beeping sound, press  to go back.





Program the capacity of the softener with menu advanced settings – capacity with following value in case of XLB setting: for maxi unit Capacity in liter: 120.000 / (incoming hardness in°fH – residual hardness in°fH) or Capacity

in liter: 66.000 / (incoming hardness in°dH – residual hardness in°dH)

for mini unit Capacity in liter: 35.000 / (incoming hardness in°fH – residual hardness in°fH) or Capacity in



liter: 19.000 / (incoming hardness in°dH – residual hardness in°dH)

- Backwash time

1. In backwash time display status, it shows  and 2-10. Press  to enter into program set mode.  and 10:00 flashes.
2. Press  &  to adjust the backwash time.







Join our mission.

Make water count.

3. Press  and you will hear a beeping sound, press  to go back.







Default: 4 min. Mini & Maxi

- Brine & slow rinse time

1. In brine & slow rinse time display status, it shows  and 3-60:00. Press  and enter into program set mode.  and 60:00 flashes.
2. Press  &  to adjust the brine & slow rinse time.
3. Press  and you will hear a beeping sound, press  to go back.







Default: 23 min. Mini / 49 min. Maxi

- Brine refill time

1. In brine refill time display status, it shows  and 4-05:00. Press  and enter into program set mode.  and 05:00 flashes.
2. Press  &  to adjust the brine refill time.
2. Press  and you will hear a beeping sound, press  to go back.







Default: 3 min. Mini / 6.5 min. Maxi.

- Fast rinse time

1. In fast rinse time display status, it shows  and 5-10:00. Press  and enter into program set mode.  and 10:00 flashes.
2. Press  &  to adjust the fast rinse time.
3. Press  and you will hear a beeping sound, press  to go back.

Default: 2 min. Mini / 5 min. Maxi

- Maximum interval regeneration days

1. In maximum interval regeneration days display status, it shows H-30. Press  and enter into program set mode.  and 30 flashes.
2. Press  &  to adjust the fast rinse time.
3. Press  to save your adjustment and press  to go back.

Default: 14 days

6.3 EXECUTING A MANUAL REGENERATION

A manual regeneration can be triggered by pushing the  button. The motor will start turning to change the valve position from “service” to the first cycle of the regeneration. The display will only show “-00-” when the electrical motor is running. After a few seconds you will see the following on the display:

Regeneration cycle 1: Backwash
Alternating with C every 15s

Regeneration Cycle 2: Brine
and Slow rinse
Alternating with C every 15s

Regeneration Cycle 3: Refill
Alternating with C every 15s

Regeneration Cycle 4: Fast rinse
Alternative with C every 15s

Join our mission.
Make water count.

7. COMMISSIONING

We recommend following steps for the commissioning of the softener. Wait to put salt in the softener till the end of the commissioning in line with the guidelines below.

- Rinsing of the piping.

Set the bypass of the softener in the position bypass. Open the main water inlet of the building. Open a faucet with cold water nearby the softener and let the water flow during several minutes. Possible impurities caused by the installation activities should be removed from the piping. Close the faucet when the water has become clear.

- Filling of the softener with water and rinsing of the resins

Start an immediate manual regeneration of the softener (See chapter programming). Skip the backwash, brining & slow rinse and fill steps by pushing the regeneration button and go immediately to the fast rinse phase. Keep the outlet of the bypass closed so no water can flow towards the user. With the bypass closed, open the main water supply at quarter position. The softener is being filled in a slow way. When the flow in the drain tube has become constant (the bottle is meanwhile full of water), open the main water completely

and let the water flow to the drain until it has become clear. Now the resins are rinsed. Put the softener in full bypass position (inlet and outlet closed). Move the valve towards service-position by pushing the regeneration button.

- Put water in the cabinet of the softener

Fill the cabinet with 5L (for mini) or 10L (for maxi) of water (where you would normally put the salt). Do not use any salt yet. This water will be needed to check the correct functioning of the suction of the valve.

- Remove possible air from the bottle

Open the inlet of the bypass, keep the outlet of the bypass closed. Start a new manual regeneration. During backwash, possible present air will be pushed to the drain. Once the flow to the drain is stable (= all air is gone), please move to the phase “brining and slow rinse” by pushing the regeneration button so the correct functioning of the suction of the valve can be checked.

- Check correct functioning of the suction of the valve

Check whether the water in the cabinet is being sucked up. All water that is situated above the aircheck (bottom part

of the float switch) should be sucked up. The water below the aircheck will stay in the cabinet.

- Fill cabinet with water and salt (for next regeneration)

Go on with the manual regeneration. Go the phase “fill” by pushing the regeneration button. There is still no salt in the cabinet. The cabinet is now filled with a quantity of water that will dissolve later on the correct amount of salt and as such create brine. Once it is verified that the cabinet is filled with the correct amount of water, the softener can be filled with salt. It will take some hours to turn the salt into brine. This brine will then be used during the next regeneration. Push the manual regeneration phase to skip the fast rinse phase. The valve is now in service position. You can open the outlet of the bypass and the softener starts delivering soft water.

- Adjust the outgoing hardness

Not all customers want to have 100% softened water. If a customer wants an outgoing hardness of a few degrees (for instance 5°fH or 3°dH), you can adjust the outgoing hardness by turning the mixing screw that is situated at the front bottom right side of the valve.



Use a hardness tester to check whether the appropriate outgoing hardness is reached. If not, further adjust the position of the mixing screw.

- Finalise the programming of the parameters

Most of the parameters are pre-programmed in the factory. A few parameters are installation dependant and can therefore only be programmed at the moment of commissioning: For more information on programming, please have a look at chapter 6 ‘Programming’

- If necessary, change the language of the display (the language of the display can only be changed by pushing the “regeneration” and “set” button simultaneously for at least 5 seconds immediately after plugging in the power adapter.
- Program the hour of the day.
- Program the capacity of the softener with menu advanced settings – capacity with following value in case

Join our mission.
Make water count.

of XLB setting:

For maxi unit Capacity in liter: 120.000

/ (incoming hardness in°fH – residual hardness in°fH) or Capacity in liter:

66.000 / (incoming hardness in°dH – residual hardness in°dH)

For mini unit Capacity in liter: 35.000

/ (incoming hardness in°fH – residual hardness in°fH) or Capacity in liter:

19.000 / (incoming hardness in°dH – residual hardness in°dH)

For instance an incoming hardness of 35°fH and an outgoing hardness of 5°fH results in a capacity of +/- 4000 Liter for a maxi unit (default value: 3600 liter)

8. TROUBLESHOOTING

Control valve display does not light up.	Power adapter not in the power plug.	
	Problem with electricity network	
	Issue with power adapter	Contact your installer
	Issue with power cable	Contact your installer
	Issue with electronic card	Contact your installer
Water is not softened	Inlet and outlet are reversed	Connect the inlet and outlet correctly
	Salt is not dissolved	Wait at least 30 minutes after having filled the softener with salt.
	No salt consumption	See further for possible reasons
	Hot water not softened	The unsoftened hot water already present in the boiler first needs to be consumed
No salt consumption	Water pressure too low	
	Injector is clogged	Contact your installer
	Not enough flow to the drain	Contact your installer
Too much brine in the salt tank <small>(not all brine is being sucked up during a regeneration)</small>	Too little water pressure in the system	Increase pressure to min. 2 bar
	Clogged injector	Contact your installer
	Parameters not set correctly	Contact your installer.
	Not enough flow to the drain	Contact your installer

Join our mission.
Make water count.

Continuous flow to the drain	Power failure during regeneration	Restore the power supply if possible. If not, close the bypass until the power is back
Noise	Air in the system	Put the system in backwash mode to have the air escaped.
Water has milk like colour	Air in the system	Put the system in backwash mode to have the air escaped.
Hard water after some days	Check value incoming and outgoing water hardness	
	Parameters not set correctly	Contact your installer
	Not enough salt during previous regeneration	

In order to avoid important, unnecessary water consumption, it is important to make a quick check of the status of the softener at least on a bi-weekly base. As regeneration happens during the night, the softener should not be sending water to the drain during the day.

Robin Classic