



Application

- Can be used to transfer clean water or other liquids similar to water in physical and chemical properties
- Suitable for small living water supply, automatic water sprinkler system, small air conditioner system or supporting equipment etc.

Pump

- Special anti-rust treatment for cast iron pump body and support
- Brass impeller
- AISI 304 shaft
- Max. liquid temperature: +60°C
- Max. suction: 8 m

Motor

- Low noise&Long life bearing
- Motor with copper winding
- Built-in thermal protector for single phase motor
- Insulation class: F
- Enclosures class: IPX4
- Max. ambient temperature: +50°C
- IE 2 motor (AP110、AP150)

Identification Codes

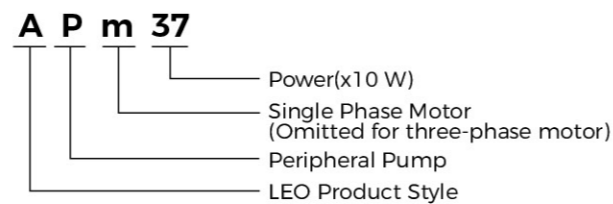

Technical Data

Model		Power		Q(m ³ /h)		H (m)															
Single Phase	Three Phase	kW	HP	Q(l/min)	0	0.3	0.6	0.9	1.2	1.5	1.8	2.1	2.4	3.0	3.6	4.2	4.8	5.4			
APm30	-	0.3	0.4		30	26	20	15	12	8	5	-	-	-	-	-	-	-	-		
APm37	-	0.37	0.5		40	35	30	25	20	15	10	5	-	-	-	-	-	-	-		
APm60	-	0.6	0.8		60	55	50	40	35	30	25	20	10	5	-	-	-	-	-		
APm75	-	0.75	1.0		75	70	60	50	45	35	28	22	15	5	-	-	-	-	-		
APm90	-	0.75	1.0		90	75	60	50	35	25	15	5	-	-	-	-	-	-	-		
APm110	AP110	1.1	1.5		85	80	75	65	60	55	50	45	40	30	18	10	-	-	-		
APm150	AP150	1.5	2.0		90	85	80	75	70	65	60	55	50	40	30	20	10	-	-		
APm220	AP220	2.2	3.0		100	95	90	85	80	75	70	65	60	50	40	30	20	10	-		

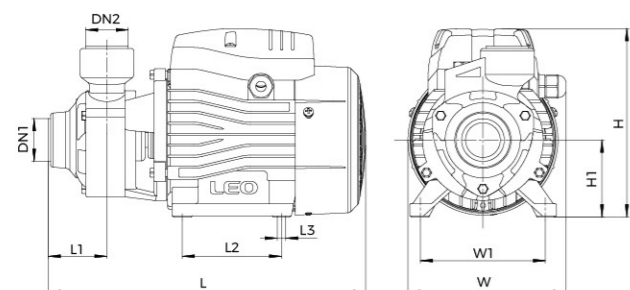

Dimension

Model	DN1	DN2	L (mm)	W (mm)	H (mm)	L1 (mm)	L2 (mm)	L3 (mm)	W1 (mm)	H1 (mm)
APm30	1"	1"	260	132	155	46.5	80	8.5	100	63
APm37	1"	1"	260	132	155	46.5	80	8.5	100	63
APm60	1"	1"	282	147	185	51	90	8.5	112	73
APm75	1"	1"	300	147	185	54.5	90	8.5	112	73
APm90	3/4"	3/4"	297	147	185	50	90	8.5	112	73
APm110	1"	1"	338	165	210	56	100	9	125	86
APm150	1"	1"	338	165	210	56	100	9	125	86
APm220	1"	1"	395	170	235	56	123	12	140	96
AP220	1"	1"	338	165	210	56	100	9	125	86

Hydraulic Performance Curves

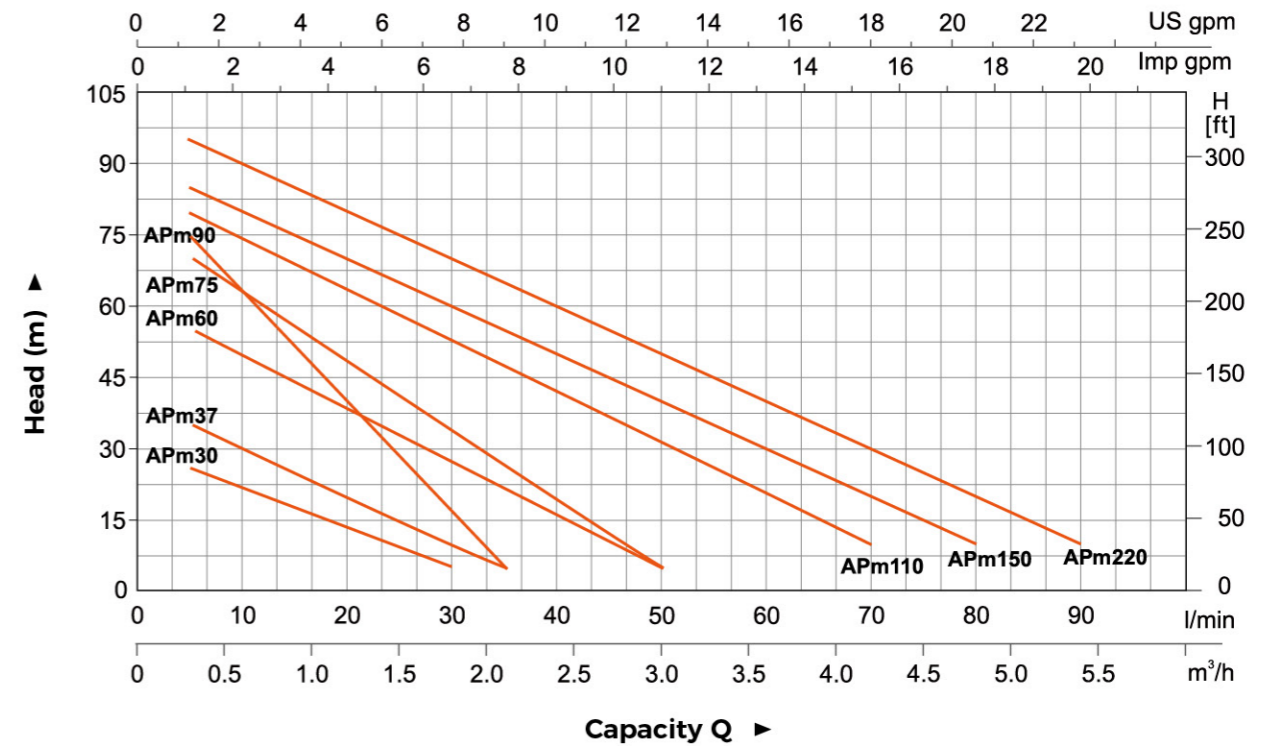

Material Table

No.	Part	Material
1	Pump body	HT200
2	Impeller	HPb59-1
3	O-ring	NBR
4	Mechanical seal	
5	Pump support	HT200
6	Bearing	
7	Rotor	
8	Fan cover	PP
9	Fan	PP-GF10
10	End plate	ADC12
11	Capacitor	
12	Cover box	PP-GF20
13	Wiring base assembly	PC
14	Stator	
15	Filling plug	HPb59-1

No.	Part	Material
14-1	Stator	
14-2	Base plate	PC+ABS

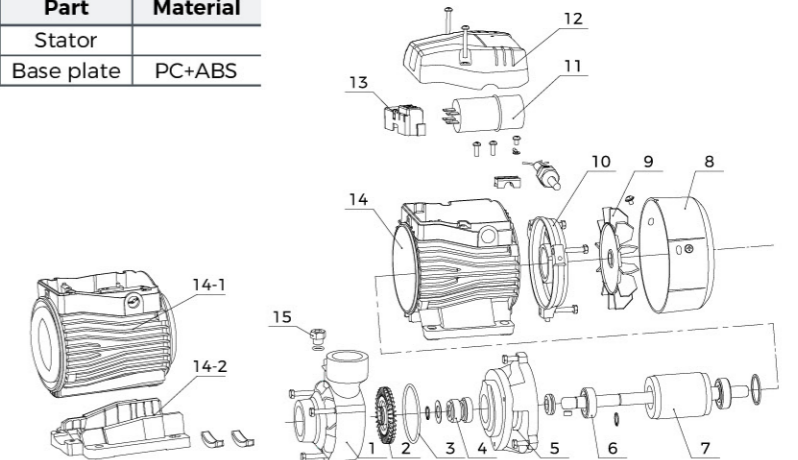

Package Information

Model	GW (Kgs)	L (mm)	W (mm)	H (mm)	Quantity (PCS/20'TEU)
APm30	5.65	283	158	174	3132
APm37	5.85	283	158	174	3132
APm60	9.5	315	190	210	2365
APm75	10.6	335	190	210	2222
APm90	10.8	335	190	210	2222
APm110	15.75	370	210	235	1230
APm150	16.85	370	210	235	1230
APm220	23.5	420	225	265	955
AP220	16.85	370	210	235	1230

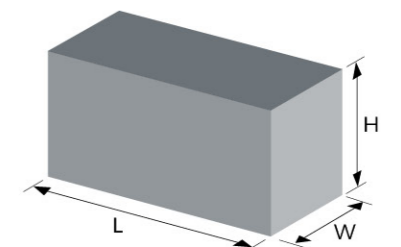



Application

- Can be used to transfer clean water or other liquids similar to water in physical and chemical properties
- Suitable for small living water supply, automatic water sprinkler system, small air conditioner system or supporting equipment etc.

Pump

- Special anti-rust treatment for cast iron pump body and support
- Anti-block system for impeller
- Brass impeller
- AISI 304 shaft
- Max. liquid temperature: +60°C
- Max. suction: +8 m

Motor

- Low noise&Long life bearing
- Motor with copper winding
- Built-in thermal protector for single phase motor
- Insulation class: F
- Enclosures class: IPX4
- Max. ambient temperature: +50°C

Identification Codes

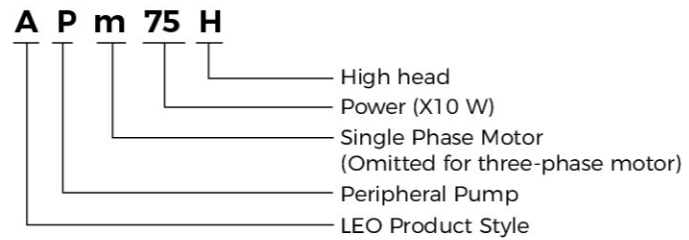

Technical Data

Model	Power		Q(m ³ /h) Q(l/min)	0	0.3	0.6	0.9	1.2	1.5	1.8	2.1	2.4	2.7	3.0
	kW	HP		0	5	10	15	20	25	30	35	40	45	50
APm75H	0.75	1.0	H (m)	105	85	70	60	40	30	20	10	-	-	-
APm110H	1.1	1.5		125	110	100	85	70	60	40	32	25	15	-

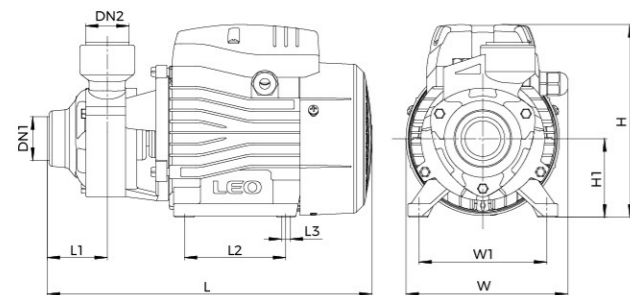

Dimension

Model	DN1	DN2	L (mm)	W (mm)	H (mm)	L1 (mm)	L2 (mm)	L3 (mm)	W1 (mm)	H1 (mm)
APm75H	3/4"	3/4"	299	147	183	52.5	90	8.5	112	73
APm110H	1"	1"	338	165	210	56	100	9	125	86

Hydraulic Performance Curves

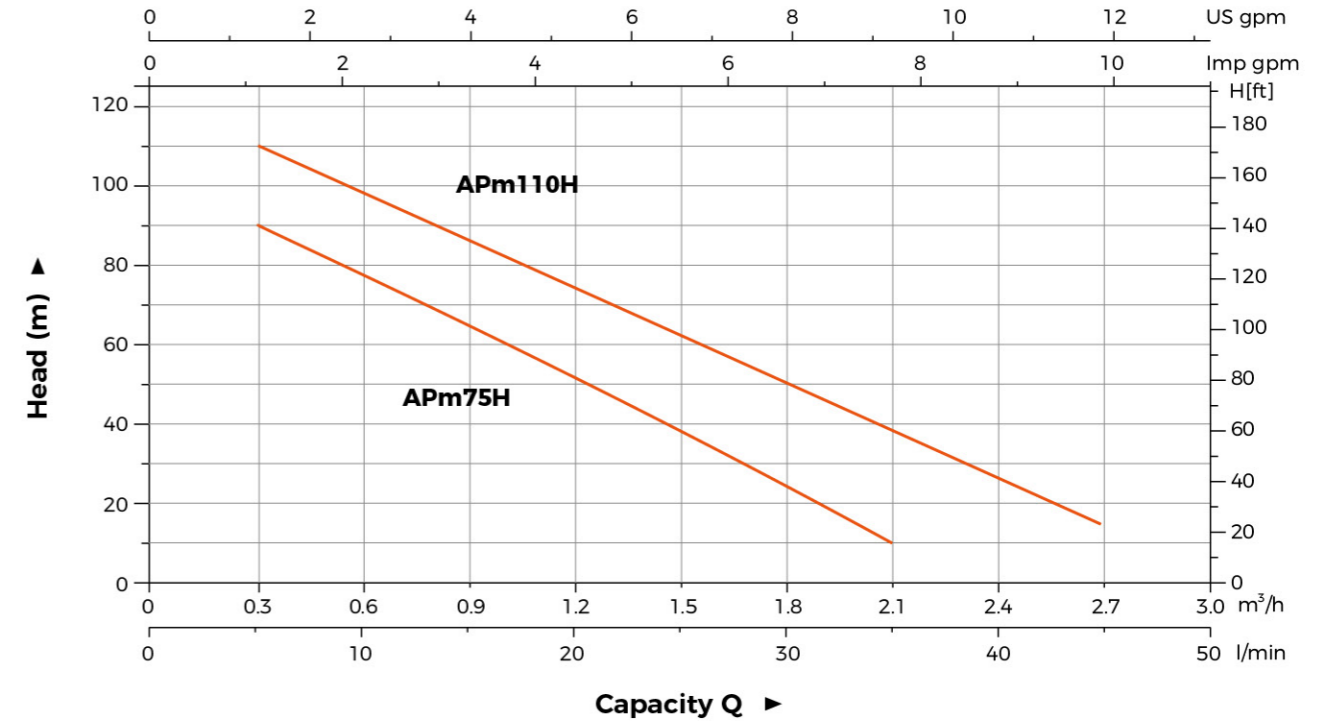

Material Table

No.	Part	Material
1	Pump body	HT200
2	Impeller	HPb59-1
3	O-ring	NBR
4	Mechanical seal	
5	Pump support	HT200
6	Bearing	
7	Rotor	
8	Fan cover	PP
9	Fan	PP-GF10
10	End plate	ADC12
11	Capacitor	
12	Cover box	PP-GF20
13	Wiring base assembly	PC
14	Stator	
15	Filling plug	HPb59-1

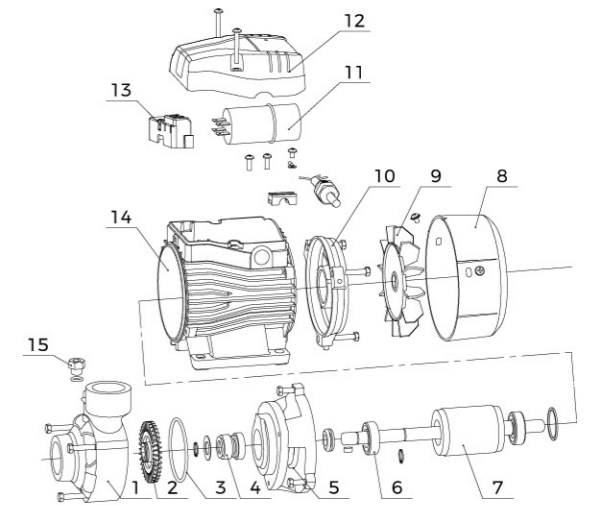

Package Information

Model	GW (Kgs)	L (mm)	W (mm)	H (mm)	Quantity (PCS/20'TEU)
APm75H	11.5	335	190	220	1851
APm110H	16.25	370	210	235	1565

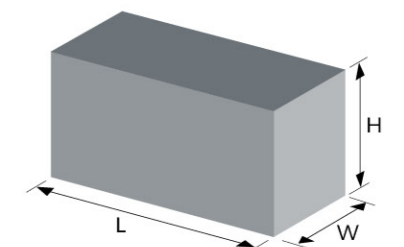



Application

- Can be used to transfer clean water or other liquids similar to water in physical and chemical properties
- Suitable for small living water supply, automatic water sprinkler system, small air conditioner system or supporting equipment etc.

Pump

- Special anti-rust treatment for cast iron pump body and support
- Brass impeller
- AISI 304 shaft
- Max. liquid temperature: +60°C
- Max. suction: +8 m

Motor

- Low noise&Long life bearing
- Motor with copper winding
- Built-in thermal protector for single phase motor
- Insulation class: F
- Enclosures class: IPX4
- Max. ambient temperature: +50°C
- IE 2 motor

Identification Codes

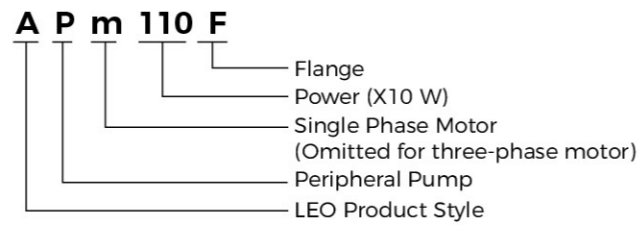

Technical Data

Model		Power		Q(m³/h)	Q(l/min)													
Single Phase	Three Phase	kW	HP	H (m)	0	0.3	0.6	0.9	1.2	1.5	1.8	2.1	2.4	3.0	3.6	4.2	4.8	
					0	5	10	15	20	25	30	35	40	50	60	70	80	
APm110F	AP110F	1.1	1.5	H	85	80	75	65	60	55	50	45	40	30	18	10	-	
APm150F	AP150F	1.5	2.0	H	90	85	80	75	65	60	55	50	45	40	30	18	10	

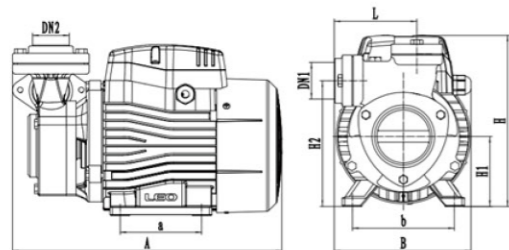

Dimension

Model	DN1	DN2	A (mm)	B (mm)	L (mm)	a (mm)	b (mm)	H (mm)	H1 (mm)	H2 (mm)
APm110F	1.25"	1.25"	330	168	100	100	125	210	86	154.5
APm150F	1.25"	1.25"	332	168	100	100	125	210	86	154.5

Hydraulic Performance Curves

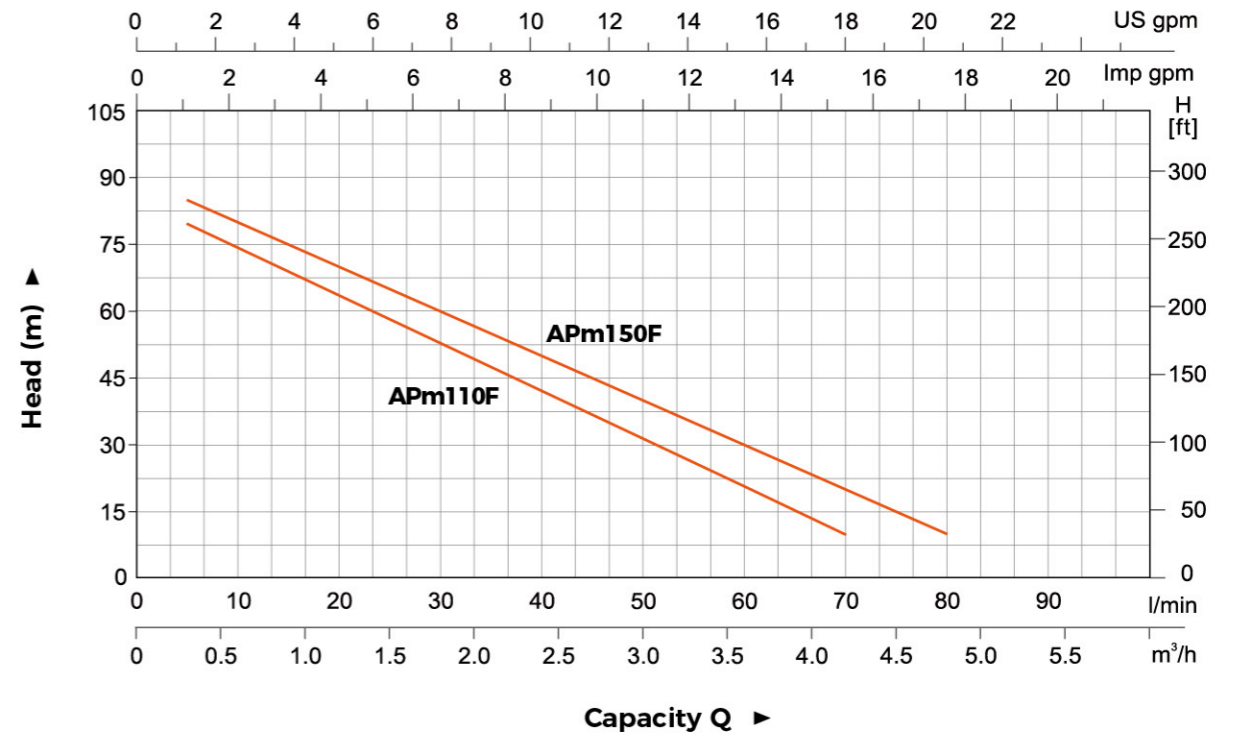

Material Table

No.	Part	Material
1	Pump body	HT200
2	Impeller	HPb59-1
3	O-ring	NBR
4	Mechanical seal	
5	Pump support	HT200
6	Bearing	
7	Rotor	
8	Fan cover	PP
9	Fan	PP-GF10
10	End plate	ADC12
11	Capacitor	
12	Cover box	PP-GF20
13	Wiring base assembly	PC
14	Stator	
15	Filling plug	HPb59-1

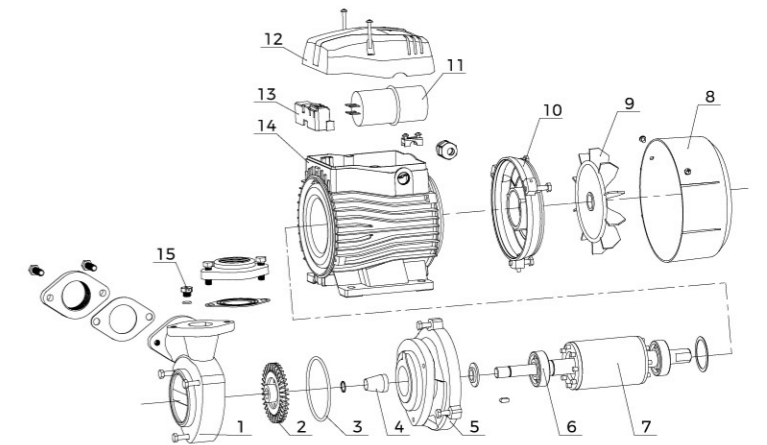

Package Information

Model	GW (Kgs)	L (mm)	W (mm)	H (mm)	Quantity (PCS/20'TEU)
APm110F	16.5	365	200	245	1240
APm150F	17.4	365	200	245	1180

