

Water Specialist AR Control Valve Programming Manual

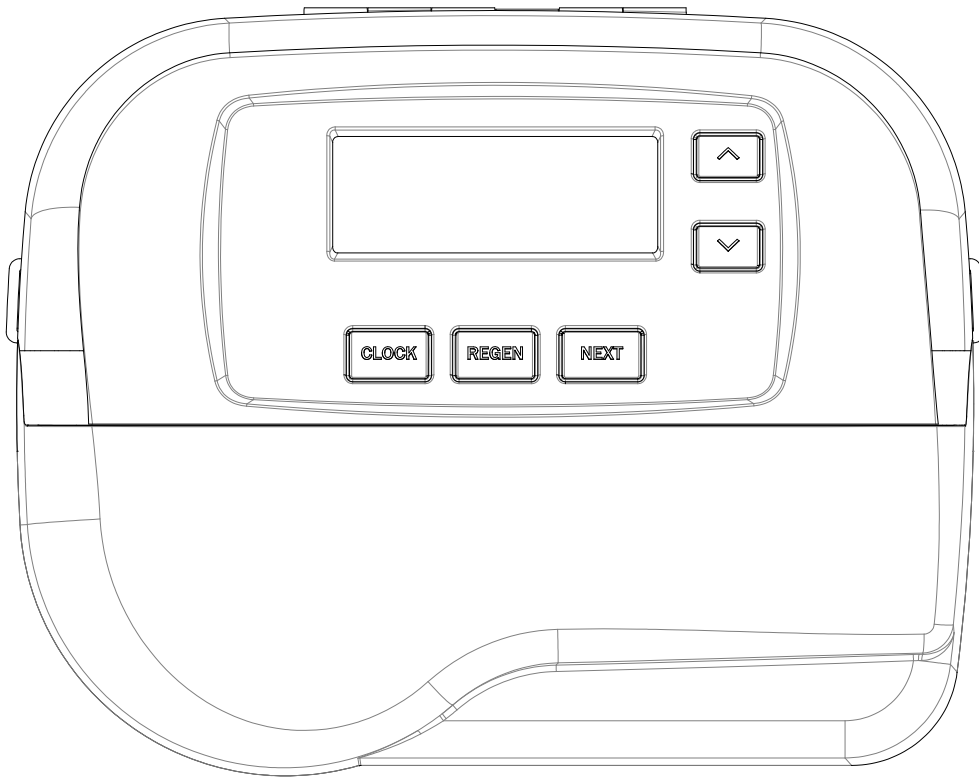

Table of Contents

Front Cover and Drive Assembly	4
OEM General Programming Instructions	5
OEM Cycle Sequence	7
OEM Softener System Setup	13
Setting Options Table	16
OEM Filter System Setup	17
Installer Display Settings	21
User Display Settings	22
Diagnostics.....	25
Valve History	27

Front Cover and Drive Assembly

Drawing No.	Order No.	Description	Quantity
1	V3665-01	WS1AQ FRONT COVER ASSEMBLY	1
2	V3107-01	WS1 MOTOR ASY	1
3	V3002-A	WS1 DRIVE BRACKET ASY	1
4	V3650AR-02BOARD	WS1 THRU 2 AR PC BRD REPL	1
5	V3110	WS1 DRIVE REDUCING GEAR 12X36	3
6	V3109	WS1 DRIVE GEAR COVER	1
Not Shown	V3186-06	WS1 POWER SUPPLY US 15VDC HOCP	1
	V3186AUS-05OD	WS1 POWER SUPPLY AUS 15VDC VI OUTDOOR	
	V3186EU-06	WS1 POWER SUPPLY EU 15VDC HOCP	
	V3186UK-06	WS1 POWER SUPPLY UK 15VDC HOCP	
	V3186-01	WS1 POWER CORD ONLY	
Not Shown	V3606	WS1 AQ DRIVE BACK PLATE	1
Not Shown	V3605	WS1 AQ OVER COVER	1
Not Shown	V3614	WS1 AQ HINGE PIN	1

Refer to Control Valve Service Manual for other drawings and part numbers.

Relay Driver Output Type – Dual Solid-State 12VDC “wet” contacts - N.O.
 Relay Driver Output Capacity - 12VDC @100mA per relay output (total current through both outputs not to exceed 200mA).

Power Supply	U.S.	International
Supply Voltage	100-120 VAC	100-240 VAC
Supply Frequency	50/60 Hz	50/60 Hz
Output Voltage	15 VDC	15 VDC
Output Current	500 mA	500 mA

NOTE: Check for proper mounting dimensions on valve backplate prior to mounting an external relay under control cover.

Wiring For Correct On/Off Operation	
PC Board Relay Terminal Block	Relay
RLY 1	Coil -
COM	Coil +
RLY 2	Coil -

When replacing the battery, align positives and push down to fully seat.

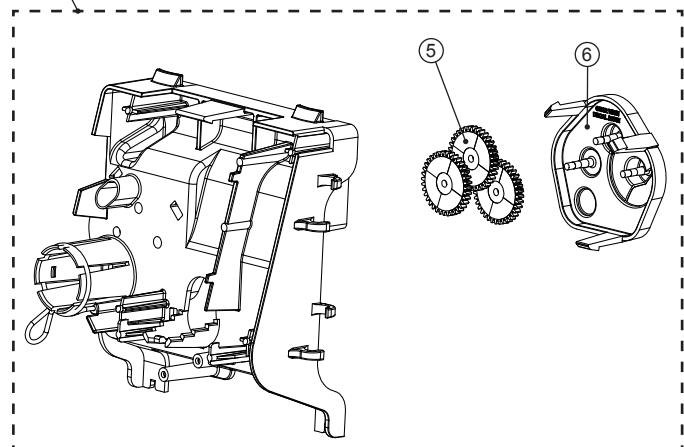
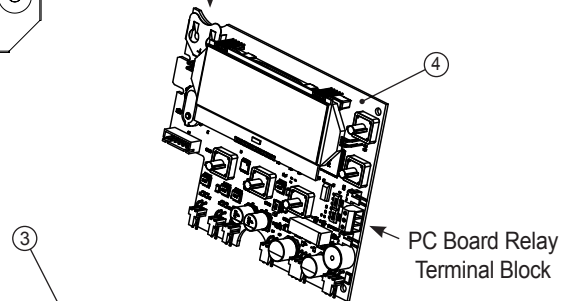
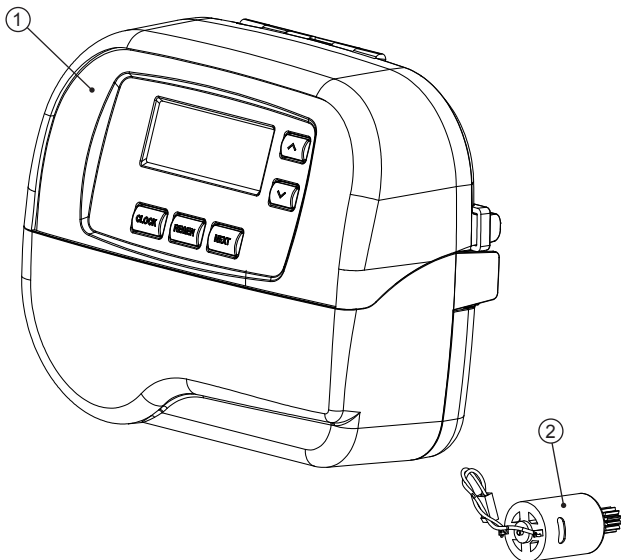
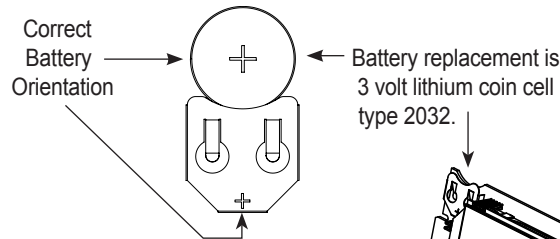
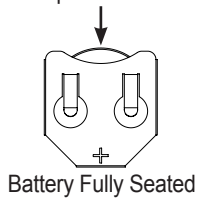

OEM General Programming Instructions

The control valve offers multiple procedures that allow the valve to be modified to suit the needs of the installation. These procedures are:

- OEM Cycle Sequence
- OEM Softener System Setup
- OEM Filter System Setup
- Installer Display Settings
- User Display Settings
- Diagnostics
- Valve History

Tables 1 and 2 show examples when the valve is set up as a softener or filter.

Table 1: Regeneration Cycles Softening

Downflow Regenerant Refill After Rinse	Downflow Regenerant Prefill	Upflow Regenerant Refill After Rinse	Upflow Regenerant Prefill
1 st Cycle: Backwash 2 nd Cycle: dn Brine 3 rd Cycle: Backwash 4 th Cycle: Rinse 5 th Cycle: Fill 6 th Cycle: End	1 st Cycle: Fill 2 nd Cycle: Softening 3 rd Cycle: Backwash 4 th Cycle: dn Brine 5 th Cycle: Backwash 6 th Cycle: Rinse 7 th Cycle: End	1 st Cycle: UP Brine 2 nd Cycle: Backwash 3 rd Cycle: Rinse 4 th Cycle: Fill 5 th Cycle: End	1 st Cycle: Fill 2 nd Cycle: Softening 3 rd Cycle: UP Brine 4 th Cycle: Backwash 5 th Cycle: Rinse 6 th Cycle: End

Table 2: Regeneration Cycles Filtering

Downflow Regenerant Refill After Rinse	Downflow Regenerant Prefill	No Regenerant
1 st Cycle: Backwash 2 nd Cycle: dn Brine 3 rd Cycle: Backwash 4 th Cycle: Rinse 5 th Cycle: Fill 6 th Cycle: End	1 st Cycle: Fill 2 nd Cycle: Filtering 3 rd Cycle: Backwash 4 th Cycle: dn Brine 5 th Cycle: Backwash 6 th Cycle: Rinse 7 th Cycle: End	1 st Cycle: Backwash 2 nd Cycle: Rinse 3 rd Cycle: Backwash 4 th Cycle: Rinse 5 th Cycle: End

The control valve with a water meter can be set for Demand Initiated Regeneration (DIR) only, Time Clock operation only or DIR and Time Clock which ever comes first, depending upon what settings are selected for Day Override and Volume Capacity.¹ See Table 3.

If a control valve does not contain a meter, the valve can only act as a time clock, and day override should be set to any number and volume capacity should be set to off.

Table 3: DIR/Time Clock Options

DIR	Time Clock	Reserve Capacity	Softener	Filter		Settings ²	
				Regenerant	Backwash Only	Days to REGEN	Volume Capacity
Yes		Automatically calculated	Yes			Off	Auto
Yes		If desired enter a value less than estimated capacity	Yes	Yes	Yes	Off	Any Number
Yes	Yes	Automatically calculated	Yes			Any Number	Auto
Yes	Yes	If desired enter a value less than estimated capacity	Yes	Yes	Yes	Any Number	Any number
	Yes	None	Yes	Yes	Yes	Any Number	Off

For DIR Softeners, there are two options for setting the Volume Capacity. The Volume Capacity is automatically calculated if set to AUTO. Reserve Capacity is automatically estimated based on water usage if AUTO is used. The other option is to set the Volume Capacity to a specific number. If a specific number is set, reserve capacity is zero, unless the value is manually set (i.e. the manufacturer intentionally sets the volume capacity number below the calculated capacity of the system).

A unique feature of this control valve is the ability to display actual water usage for the last 63 days. The values are initially stored as “----”. This means the value is unknown. As days pass values are stored as “0” for no flow or the actual number of cubic meters. The counting of the cubic meters starts at the regeneration time. If no regeneration time can be set (i.e. when the valve is set for immediate regeneration) the counting of cubic meters starts at 12 a.m. Day 1 is yesterday, day 2 the day before yesterday, etc. As new values are added the oldest history disappears.

Another unique feature is that the valve automatically calculates a reserve capacity when set up as a softener with “m³ Capacity” set to “AUTO” and the “Regeneration Time Option” set to “DELAYED REGEN” or “BOTH”. The actual reserve capacity is compared to the capacity remaining immediately prior to the preset regeneration time. A regeneration will occur if the actual reserve capacity is less than the capacity remaining. The actual reserve capacity is calculated by using the estimated reserve capacity and adjusting it up or down for actual usage.

The estimated reserve capacity for a given day of the week is the maximum value stored for the last three non-trivial water usages (i.e. more than 0.08 m³/day) in seven day intervals.

¹ See Installer Display Settings, OEM Softener System Setup and OEM Filter System Setup for explanations of Day Override and Volume Capacity.

² Days to REGEN and Volume Capacity can not both be set to “OFF” at the same time.

Once the OEM Cycle Sequence has been set, the other procedures can be accessed in any order. Details on each of the procedures are provided on the following pages.

To “lock out” access to diagnostic and valve history displays and modifications to settings except hardness, day override, time of regeneration and time of day by anyone but the manufacturer, press ▼, NEXT, ▲, and CLOCK in sequence after settings are made. To “unlock”, so other displays can be viewed and changes can be made, press ▼, NEXT, ▲, and CLOCK in sequence.

When in operation normal user displays such as time of day, volume remaining before regeneration, present flow rate or days remaining before regeneration are shown. When stepping through a procedure, if no buttons are pressed within five minutes, the display returns to a normal user display. Any changes made prior to the five minute time out are incorporated.

To quickly exit OEM Softener Setup, OEM Filter Setup, Installer Display Settings, Diagnostics or Valve History press CLOCK. Any changes made prior to the exit are incorporated.

To clear the Service Call reminder, press ▲ and ▼ simultaneously while the reminder screen is displayed.

When desired, all programming and information in Diagnostics may be reset to defaults when the valve is installed in a new location. To reset, press NEXT and ▼ simultaneously to go to the Softening/Filtering screen. Press ▲ and ▼ simultaneously to reset programming and diagnostic values. Screen will return to User Display.

Sometimes it is desirable to have the valve initiate and complete two regenerations within 24 hours and then return to the preset regeneration procedure. It is possible to do a double regeneration if the control valve is set to “DELAYED REGEN” or “BOTH” in OEM Softener System Setup or OEM Filter System Setup. To do a double regeneration:

1. Press the “REGEN” button once. REGEN TODAY will flash on the display.
2. Press and hold the “REGEN” button for three seconds until the valve regeneration initiates.

Once the valve has completed the immediate regeneration, the valve will regenerate one more time at the preset regeneration time.

For Valve Type 1.0T, press and hold SET and ▲ for about 3 seconds to initiate an exchange of the tank in Service without cycling the regeneration valve. After tank switch, days remaining and capacity remaining status is retained for each tank until the next regeneration.

Prior to selecting the upflow regeneration cycle, verify that the correct body, main piston, regenerant piston and stack are being used, and that the injector plug(s) are in the correct location. Refer to the Service Manual for drawings and part numbers.

Proportional Brining

If the system is set up as a prefill upflow softener, the control valve can also be set to normal or proportional brining.

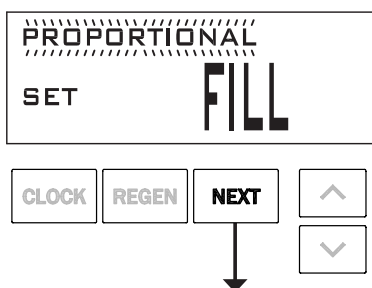

This step will appear after Step 7S and before Step 8S if the system is set up as a prefill upflow softener. The following options can be selected:

- NORMAL FILL - System always prefills with the salt level selected.
- PROPORTIONAL FILL - If proportional brining is selected, the actual salt fill time will be calculated by dividing the actual volume of treated water used by the full volumetric capacity, then multiplying this value by the maximum salt fill time.

Press NEXT to go to the next step. Press REGEN to return to the previous step.

OEM Cycle Sequence

OEM Cycle Sequence instructions allows the OEM to set the order of the cycle. The OEM Softener System Setup or the OEM Filter System Setup allow the OEM to set how long cycles will last. The OEM may choose up to 9 cycles in any order. **END must be used as the last cycle option.** The SERVICE cycle should only be used in brine prefill applications.

The following is an example of how to set a valve so that when regeneration is initiated BACKWASH occurs first, dn BRINE occurs second, RINSE occurs third, and FILL occurs fourth.

STEP 1CS

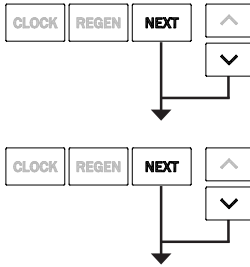

Step 1CS – Press NEXT and ▼ simultaneously for 3 seconds and release. Then press NEXT and ▼ simultaneously for 3 seconds and release. If screen in Step 2CS does not appear in 5 seconds the lock on the valve is activated. To unlock press ▼, NEXT, ▲, and CLOCK in sequence, then press NEXT and ▼ simultaneously for 3 seconds and release. Then press NEXT and ▼ simultaneously for 3 seconds and release.

STEP 2CS

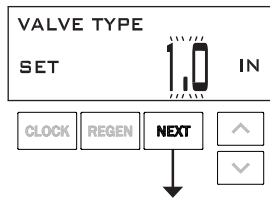

Step 2CS – Use ▲ or ▼ to select 1.0 for 1” valve, 1.25 for 1.25” valve, 1.5 for 1.5” valve, 2.0 for 2” valve or 1.0T for twin valve.
Press NEXT to go to Step 3CS.
Press REGEN to exit OEM cycle sequence.

STEP 3CS

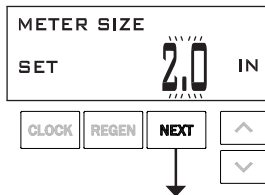

Step 3CS – When 1.5 or 2.0 is selected, an additional screen will appear. It is used to select which size flow meter is to be used with the valve, 1.0r, 1.5, 2.0 or 3.0.
Press NEXT to go to Step 4CS.
Press REGEN to return to previous step.

STEP 4CS

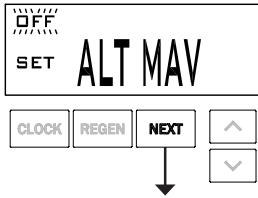

Step 4CS – Allows selection of one of the following using ▲ or ▼ :

- the Control Valve to act as an alternator; or
- the Control Valve to have a no hard water bypass: or
- the Control Valve to have a Separate Source during the regeneration cycle; or
- the Control Valve to operate with the Clack System Controller.

Select OFF when none of these features are used.

Only use Clack No Hard Water Bypass Valves or Clack Motorized Alternating Valves (MAV) with these selections. Clack No Hard Water Bypass Valves (1” or 1.25” V3070FF or V3070FM) are not designed to be used with the alternator function or separate source mode.

Selecting the Control Valve to act as an alternator:

Prior to starting the programming steps, connect the communication cable to each control valve board’s three pin connector labeled ‘COMM CABLE’. Also connect the meter cord to either control valve to the three pin connector labeled ‘METER’.			
Softener Valve Programming Steps			
OEM Cycle Sequence	Step 4CS	Set to VALVE A Connect the outlet plumbing of VALVE A valve to the MAV’s A port and connect the MAV’s two pin wire connector to the two pin connector labeled “MAV” on VALVE A	Set to VALVE B Connect the outlet plumbing of VALVE B valve to the MAV’s B port. No electrical connections are required between the VALVE B and the MAV.
OEM System Setup	Step 7S	Set System Capacity	Set System Capacity
OEM System Setup	Step 8S	Set to ‘AUTO’	Set to ‘AUTO’
OEM System Setup	Step 9S	Set regeneration time option to ‘IMMEDIATE REGEN’.	Set regeneration time option to ‘IMMEDIATE REGEN’.
Installer Display Settings	Step 5I	Set Day Override to “OFF”	Set Day Override to “OFF”

If set up for a filter, in Step 7F set Volume Capacity in m³; in Step 8F select Regeneration Time Option “Immediate”; and in Step 3I select Day Override “oFF”.

For Clack Corporation alternator systems using **WS1, WS1.25 or WS1.5** valves there will be an option to delay the last two cycles of regeneration (only “Rinse” and “Fill”). This feature splits the regeneration into two portions. The first portion of the regeneration will start immediately and all programmed cycles before the “Rinse” and “Fill” cycles will be performed. After all programmed cycles before “Rinse” and “Fill” are completed the control valve will drive to the service position (displaying “Delayed Rinse + Fill Pending”). When the volume of the on-line unit is depleted to 10% of its programmed capacity, the control valve will be triggered to finish the second portion of the regeneration. Once “Rinse” and “Fill” are completed, the valve will re-enter Standby mode until requested to come on-line for Service.

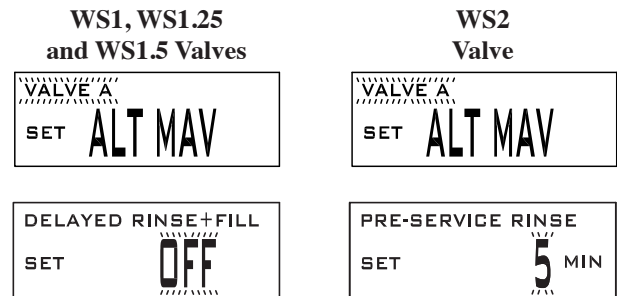

For Clack Corporation alternator systems using the **WS2** valve, when NEXT is pressed after selecting VALVE A or VALVE B, a display will allow the user to set the amount of pre-service rinse time for the stand by tank just prior to returning to service.

With 1.0T set, the same display appears and is set in a similar manner.

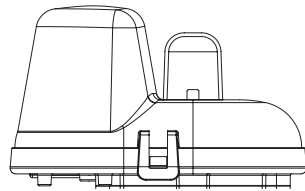
**Retracted**

Valve "A" in Service Position =
MAV piston rod Retracted

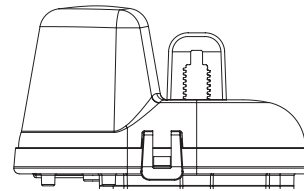
**Extended**

Valve "B" in Service Position = MAV
piston rod Extended

Note: Clack Twin Alternator Operations

- Twin alternating systems can be programmed with a day override setting combined with the normal volume-based regeneration programming. A twin alternating system in this configuration will then regenerate based on the volume used or the day override if there is a period of low water usage.
- Twin alternating systems can be programmed as a time clock only based regenerating system. In this configuration, the days remaining are counted only on the unit that is in service. The unit in Stand-by Mode only notes days in diagnostics, which results in time clock only twin regeneration initiation.
- Twin alternating systems can be programmed for a delayed regeneration time. The system will allow an immediate transfer of the MAV to switch tanks and place a fully regenerated unit in service once a unit becomes exhausted. The exhausted unit will then be placed into Stand-by Mode and allowed to have a delayed regeneration at the pre-set time.

Configuring the Control Valve for No Hard Water Bypass Operation:

Select NO HARD BYPASS for control operation. For no hard water bypass operation the three wire connector is not used. Selection requires that a connection to MAV or a Clack No Hard Water Bypass Valve is made to the two pin connector labeled MAV MTR located on the printed circuit board. If using a MAV, the A port of the MAV must be plugged and the valve outlet connected to the B port. When set to No Hard Water Bypass the MAV will be driven closed before the first regeneration cycle that is not FILL or SOFTENING or FILTERING, and be driven open after the last regeneration cycle that is not FILL.

NOTE: If the control valve enters into an error state during regeneration mode, the no hard water bypass valve will either remain in Service or be returned to Service until the error is corrected and reset.



Configuring the Control Valve for Separate Source Operation:

Select Separate Source for control operation. For separate source operation, the three wire connector is not used. Selection requires that a connection to a Clack Motorized Alternator Valve (MAV) is made to the two pin connector labeled MAV MTR located on the printed circuit board. The C port of the MAV must be connected to the valve inlet and the A port connected to the separate source used during regeneration. The B port must be connected to the feed water supply.

When set to Separate Source the MAV will be driven closed before the first regeneration cycle, and be driven open after the last regeneration cycle.

NOTE: If the control valve enters into an error state during regeneration mode, the MAV will either remain in Service or be returned to Service until the error is corrected and reset.



Configuring the Control Valve to operate with Clack System Controller:

Select System Board Enabled to link the Control Valve to the Clack System Controller. For communication between the Control Valve and the System Controller a three wire communication cable is required.

Press NEXT to go to Step 5CS. Press REGEN to return to previous step.



STEP 5CS

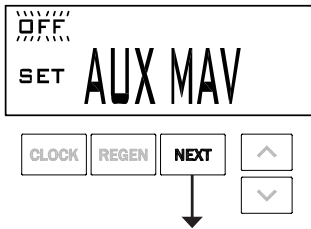

Step 5CS – Set Auxiliary Drive Output (MAV only) to operate in one of three modes:

- Set TIME: Allows Auxiliary MAV to switch positions at a set time in relation to the start of regeneration for a preset duration, independently of the actual regeneration status.
- Set SEPARATE SOURCE: Allows Auxiliary MAV to switch positions before the start of regeneration and then switch back at the end of regeneration.
- Set OFF: Deactivates this output.

Only use Clack Motorized Alternating Valves (MAV) with these selections. Clack No Hard Water Bypass Valves (1" or 1.25" V3070FF or V3070FM) are not designed to be used with the "TIME" or "SEPARATE SOURCE" modes.

Press NEXT to go to Step 6CS. Press REGEN to return to previous step.

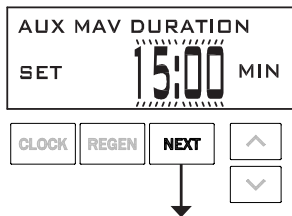
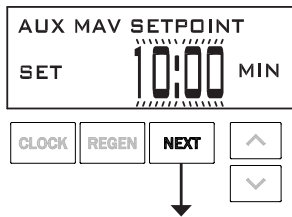
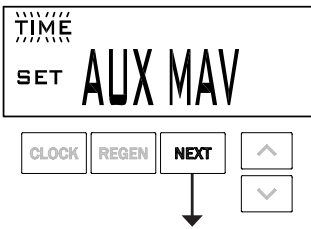

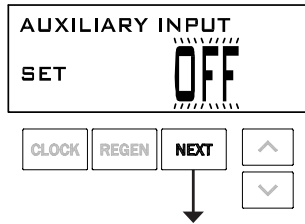
STEP 6CS

Step 6CS – This allows the use of an outside signal to control the initiation of a regeneration. Selection only matters if a connection is made to the two pin connector labeled DP SWITCH located on the printed circuit board. Following is an explanation of the options:

oFF – Feature not used.

NOTE: In a twin alternating system each control must have a separate dP signal or dP switch. One dP signal or one dP switch cannot be used for both controls.

IMMED REG – If the dP switch is closed for an accumulative time of 2 minutes a regeneration will be signaled to the unit. In a twin alternating system the MAV will transition first to switch units so that the signaled unit can start regeneration. After the MAV is fully transitioned the regeneration begins immediately. Note: For WS1 – WS1.5 control valves programmed for twin alternating: if the dP function “IMMED REG” is set, the Delayed Rinse and Fill feature is not available.

DELAY REG – If the dP switch is closed for an accumulative time of 2 minutes a regeneration will occur at the scheduled delayed regeneration time. In a twin alternating system once the dP switch is triggered the PC Board will display “REGEN TODAY” and when the delayed regen time comes the control will switch tanks and the triggered unit will then go into regeneration. Note: For WS1 – WS1.5 control valves programmed for twin alternating: if the dP function “DELAY REG” is set, the Delayed Rinse and Fill feature is not available.

HOLD REG – If the dP switch is closed a regeneration will be prevented from occurring while there is switch closure. In a twin alternating system the regeneration of a unit can be prevented upon switch closure. If the unit depletes the capacity down to zero it will not be allowed to switch tanks to regenerate until the switch is open. Note: For WS1 – WS1.5 control valves programmed for twin alternating the Delayed Rinse and Fill feature can be set in conjunction with the “HOLD REG” if desired.

Press NEXT to go to Step 7CS. Press REGEN to return to previous step.

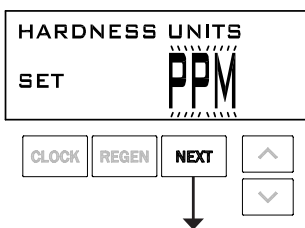
STEP 7CS

Step 7CS – Determine the measurement to calculate volumetric capacity. The choices are:

PPM parts per million

FH French degrees

dH German degrees

Press NEXT to go to Step 8CS. Press REGEN to return to previous step.

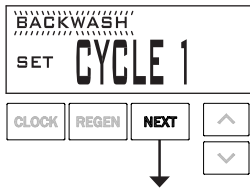
STEP 8CS

Step 8CS – Press ▲ or ▼ until BACKWASH appears. Press NEXT to go to Step 9CS. Press REGEN to return to previous step.

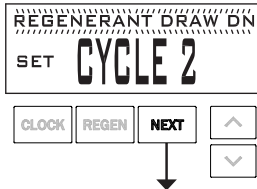
STEP 9CS

Step 9CS - Press ▲ or ▼ until Regenerant Draw DN appears. For a WS1 control valve prior to selecting DN or UP or not selecting a regenerant flow cycle, verify the correct valve body, main piston, regenerant piston and stack are being used and the injector or injector plug(s) are in the correct location. Press NEXT to go to Step 10CS. Press REGEN to return to previous step.

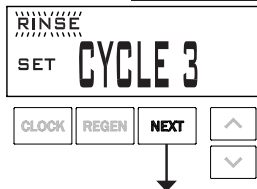
STEP 10CS

Step 10CS - Press ▲ or ▼ until RINSE appears. Press NEXT to go to Step 11CS. Press REGEN to return to previous step.

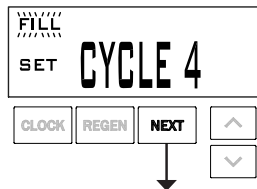
STEP 11CS

Step 11CS - Press ▲ or ▼ until FILL appears. Press NEXT to go to Step 12CS. Press REGEN to return to previous step.

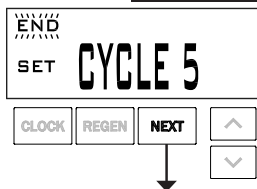
STEP 12CS

Step 12CS - Press ▲ or ▼ until END appears. Press NEXT to exit OEM Cycle Sequence. Press REGEN to return to previous step.

RETURN TO NORMAL MODE**Last Step of OEM Cycle Sequence**

Fill Units: if Step 2CS is set to 1.5, and FILL is part of the Regeneration Cycle Sequence, FILL UNITS of MIN or kg can be selected.



OEM Softener System Setup

In OEM Softener System Setup the OEM chooses the time for the cycles selected in OEM Cycle Sequence and specifies other operating parameters for the system. The upper and lower limits of the allowable values for the cycles are as follows:

Cycle Options	Units	Lower/Upper Limit
Backwash	Minutes	1 to 120
Rinse (fast)	Minutes	1 to 120
Regenerant DRAW DN (combination of brining and slow rinse)	Minutes	1 to 180
Regenerant DRAW UP (combination of brining and slow rinse)	Minutes	1 to 180
Fill for all valves except WS2	Kg	0.05 to 100
Fill for WS2 valves or WS1.5 set to "MIN"	Minutes	0.1 to 99
Service	Minutes	1 to 480

Note: Fill is in Kg of salt (except for WS2 valves).

Since no time is associated with the END cycle, the END cycle will not appear in the OEM Softener System Setup sequence.

STEP 1S

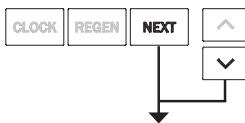

Step 1S – Press NEXT and ▼ simultaneously for 3 seconds and release. If screen in Step 2S does not appear in 5 seconds the lock on the valve is activated. To unlock press ▼, NEXT, ▲, and CLOCK in sequence, then press NEXT and ▼ simultaneously for 3 seconds and release.

STEP 2S

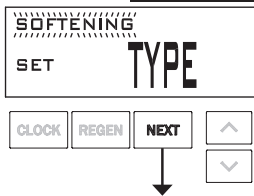

Step 2S – Choose SOFTENING using ▲ or ▼. Press NEXT to go to Step 3S. Press REGEN to exit OEM Softener System Setup.

STEP 3S

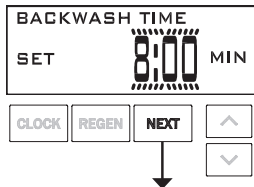

Step 3S – Select the time for the first cycle (which in this example is BACKWASH) using ▲ or ▼. Press NEXT to go to Step 4S. Press REGEN to return to previous step.

STEP 4S

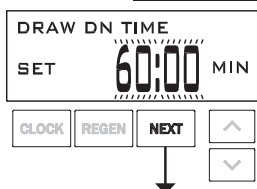

Step 4S – Select the time for the second cycle (which in this example is DRAW) using ▲ or ▼. Press NEXT to go to Step 5S. Press REGEN to return to previous step.

STEP 5S

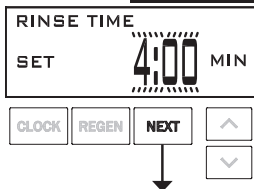

Step 5S – Select the time for the third cycle (which in this example is RINSE) using ▲ or ▼. Press NEXT to go to Step 6S. Press REGEN to return to previous step.

STEP 6S

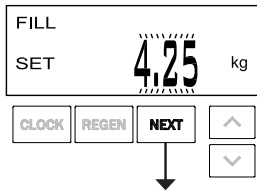

Step 6S – Select the kg for the fourth cycle (which in this example is FILL) using ▲ or ▼. When 2.0 is selected in Step 2CS, FILL is in minutes. If 1.5 is selected in Step 2CS, setting the last step of the OEM Cycle Sequence determines if the value here is kg or minutes. Press NEXT to go to Step 7S. Press REGEN to return to previous step.

STEP 7S

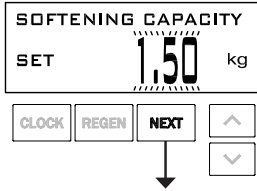

Step 7S –Set System Capacity using▲ or ▼. See chart. The System Capacity setting should be based on the volume of resin and kg of salt fill set in Step 6S. The system capacity and hardness levels entered are used to determine the Volume Capacity. Press NEXT to go to Step 8S. Press REGEN to return to previous step.

Setting	Units	Limits	Default
PPM	kg	.10-200	1.50
°fH	m ³	1-6000	160 m ³
°dH	m ³	1-6000	80 m ³

STEP 8S

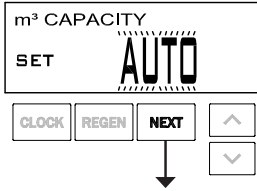

Step 8S – Set Regeneration Trigger using ▲ or ▼. If value is set to:

- “AUTO” capacity will be automatically calculated and reserve capacity will be automatically estimated;
- “OFF” regeneration will be based solely on the day override set (see Installer Display Settings Step 5I); or
- a number, regeneration initiation will be based off the value specified.

If “OFF” or a number is used, hardness display will not be allowed to be set in Installer Display Settings Step 3I. If “OFF” is selected, Regeneration Time is automatically “Delayed”, so Step 9S will not appear. See Setting Options Table for more detail. Press NEXT to go to Step 9S. Press REGEN to return to previous step.

STEP 9S

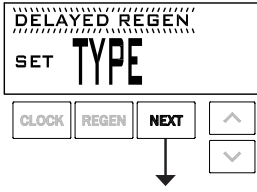

Step 9S – Set Regeneration Time Options using ▲ or ▼. If value is set to:

- “DELAYED REGEN” means regeneration will occur at the preset time;
- “IMMEDIATE REGEN” means regeneration will occur immediately when the volume capacity reaches 0 (zero); or
- “BOTH” means regeneration will occur at one of the following:
 - the preset time when the volume capacity falls below the reserve or the specified number of days between regenerations is reached whichever comes first; or
 - immediately after 10 minutes of no water usage when the volume capacity reaches 0 (zero).
- “DELAYED REGEN is the default if Step 4CS is set to VALVE A or VALVE B, and “BOTH” will not be available.
- “IMMEDIATE REGEN” is the default if Step 2CS is set to 1.0T, and “BOTH” is not available.

This step will not appear if Step 8S is set to OFF or Step 4CS is set to “SYSTEM CONTROLLER”. See Setting Options Table for more detail. Press NEXT to go to Step 10S. Press REGEN to return to previous step.

STEP 10S

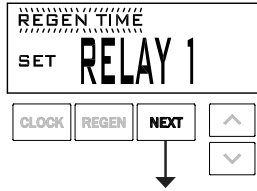

Step 10S: Set Relay 1 operation using ▲ or ▼. The choices are:

- Set REGEN TIME: Relay activates after a set time at the beginning of a regeneration and then deactivates after a set period of time. The start of regeneration is defined as the first backwash cycle or Regenerant Draw UP (1” only) or DN, which ever comes first.
- Set VOLUME: Relay activates after a set volume has been used while in service, then deactivates after the meter stops registering flow and the set time period has expired.
- Set REGEN VOLUME: Relay activates after a set volume has been used while in service or during regeneration, then deactivates after the meter stops registering flow and the set time period has expired.
- Set OFF: If set to Off, Steps 11S and 12S will not be shown.

Press NEXT to go to Step 11S. Press REGEN to return to previous step.

STEP 11S

RELAY 1 SETPOINT	
SET	10 MIN
CLOCK	REGEN
NEXT	▲
	▼

Step 11S: Set Relay 1 SETPOINT Time or Volume using ▲ or ▼. The choices are:

- Relay Actuation Time: After the start of a regeneration the amount of time that should pass prior to activating the relay. The start of regeneration is defined as the first backwash cycle or Regenerant Draw UP or DN, which ever comes first. Ranges from 0 to 500 minutes.
- Relay Actuation Volume: Relay activates after a set number of liters have passed. Ranges from 1 to 200 liters.

Press NEXT to go to Step 12S. Press REGEN to return to previous step.

STEP 12S

RELAY 1 DURATION	
SET	5:00 MIN
CLOCK	REGEN
NEXT	▲
	▼

Step 12S: Set Relay DURATION TIME using ▲ or ▼.

- If TIME is selected in Step 10S, the relay will deactivate after the time set has expired. Ranges from 0:01 to 500:00 minutes.
- If Volume or REGEN Volume is selected in Step 10S, the relay will deactivate after the time set has expired.

Press NEXT to go to Step 13S. Press REGEN to return to previous step.

STEP 13S

RELAY 2	
SET	RELAY 2
CLOCK	REGEN
NEXT	▲
	▼

Step 13S: Set Relay 2 operation using ▲ or ▼. The choices are the same as Step 10S, with the addition of Error Monitor. When Error Monitor is selected, Relay 2 closes whenever the valve enters the Error Mode, and immediately deactivates when Error Mode is exited.

- If set to Off or ERROR MONITOR, Steps 14S and 15S will not be shown.

Press NEXT to go to Step 14S. Press REGEN to return to previous step.

STEP 14S

RELAY 2 SETPOINT	
SET	20 L
CLOCK	REGEN
NEXT	▲
	▼

Step 14S: Set Relay 2 SETPOINT Time or Volume using ▲ or ▼. The choices are the same as Step 11S.

Press NEXT to go to Step 15S. Press REGEN to return to previous step.

STEP 15S

RELAY 2 DURATION	
SET	5:00 MIN
CLOCK	REGEN
NEXT	▲
	▼

Step 15S: Set Relay DURATION TIME using ▲ or ▼.

- If TIME is selected in Step 13S the relay will deactivate after the time set has expired.
- If Volume or REGEN Volume is selected in Step 13S the relay will deactivate after the time set has expired or after the meter stops registering flow, whichever comes first.

Press NEXT to go to Step 16S. Press REGEN to return to previous step.

STEP 16S

SERVICE ALARM	
SET	OFF
CLOCK	REGEN
NEXT	▲
	▼

Step 16S: Set Service Alarm using ▲ or ▼. The choices are Time, m³, BOTH or OFF. Selecting OFF disables this feature. If OFF is selected press NEXT to exit OEM System Setup. If TIME, m³ or BOTH is selected press NEXT to select the TIME and/or m³ values. Press REGEN to return to previous step.

NOTE: To clear the Service Call reminder, press ▲ and ▼ simultaneously while the reminder screen is displayed.

RETURN TO NORMAL MODE

Setting Options Table³

System Type	Regeneration Option	Regeneration Type	Day Override	
Softening	Auto	Delayed	1-28 days	Regeneration occurs at the next regeneration time when volume capacity falls below the reserve capacity, or the specified number of days is reached, whichever comes first.
Softening	Auto	Delayed	OFF	Regeneration occurs at the next regeneration time when volume capacity falls below the reserve capacity.
Softening or Filtering	0.02 – 5700.0 m ³	Delayed	1-28 days	Regeneration occurs at the next regeneration time when volume capacity reaches 0, or the specified number of days is reached, whichever comes first.
Softening or Filtering	0.02 – 5700.0 m ³	Delayed	OFF	Regeneration occurs at the next regeneration time when volume capacity reaches 0.
Softening or Filtering	OFF	Delayed	1-28 days	Time Clock operation. Regeneration occurs at the next regeneration time the specified number of days is reached.
Softening	Auto or 0.02 – 5700.0 m ³	Immediate	1-28 days	Regeneration occurs immediately when volume capacity reaches 0, or the specified number of days is reached, whichever comes first.
Softening or Filtering	0.02 – 5700.0 m ³	Immediate	OFF	Regeneration occurs immediately when volume capacity reaches 0.
Softening	Auto	Both	1-28 days	Regeneration occurs at the next regeneration time when volume capacity falls below the reserve capacity, or the specified number of days is reached, or regeneration occurs after 10 minutes of no water usage when volume capacity reaches 0.
Softening or Filtering	0.02 – 5700.0 m ³	Both	1-28 days	Regeneration occurs at the next regeneration time the specified number of days is reached or regeneration occurs after 10 minutes of no water usage when volume capacity reaches 0.
Softening	Auto	Both	OFF	Regeneration occurs at the next regeneration time when volume capacity falls below the reserve capacity, or regeneration occurs after 10 minutes of no water usage when volume capacity reaches 0.

³ Reserve Capacity estimate is based on history of water usage. Reserve Capacity estimate is not available with alternator systems or Twin Tank Valve.

OEM Filter System Setup

In OEM Filter System Setup the OEM chooses the time for the cycles selected in OEM Cycle Sequence and specifies other operating parameters for the system. The upper and lower limits of the allowable values for the cycles are as follows:

Cycle Options	Units	Lower/Upper Limit
Backwash	Minutes	1 to 120
Rinse (fast)	Minutes	1 to 120
Regenerant Draw DN (combination of regenerant and slow rinse)	Minutes	1 to 180
Fill for all valves except WS2	Liters	0.2 to 76.00
Fill for WS2 valves	Minutes	0.1 to 99
Service	Minutes	1 to 480

NOTE: Fill is in liters (except for WS2 valves).

Since no time is associated with the END cycle, the END cycle will not appear in the OEM Filter System Setup sequence.

STEP 1F

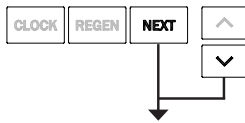

Step 1F – Press NEXT and ▼ simultaneously for 3 seconds and release. If screen in Step 2F does not appear in 5 seconds the lock on the valve is activated. To unlock press ▼, NEXT, ▲, and CLOCK in sequence, then press NEXT and ▼ simultaneously for 3 seconds and release.

STEP 2F

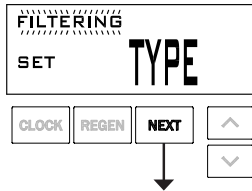

Step 2F – Choose FILTERING using ▼ or ▲. Press NEXT to go to Step 3F. Press REGEN to exit OEM Filter System Setup.

STEP 3F

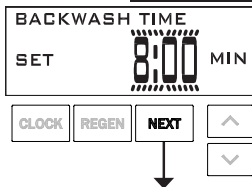

Step 3F – Select the time for the first cycle (which in this example is BACKWASH) using ▼ or ▲. Press NEXT to go to Step 4F. Press REGEN to return to previous step.

STEP 4F

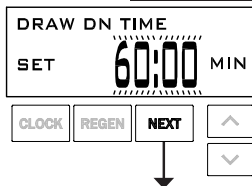

Step 4F – Select the time for the second cycle (which in this example is DRAW) using ▼ or ▲. Press NEXT to go to Step 5F. Press REGEN to return to previous step.

STEP 5F



Step 5F – Select the time for the third cycle (which in this example is RINSE) using ▼ or ▲. Press NEXT to go to Step 6F. Press REGEN to return to previous step.

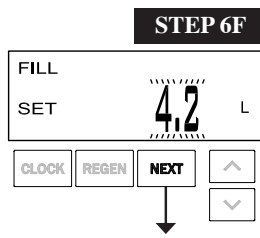

Step 6F – Select the liters for the fourth cycle (which in this example is FILL) using ▼ or ▲. When 2.0 is selected in Step 2CS, FILL is in minutes. Press NEXT to go to Step 7F. Press REGEN to return to previous step.

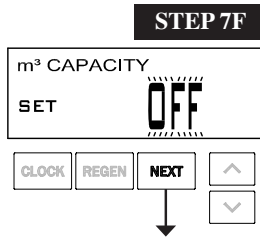

Step 7F – Set Regeneration Trigger using ▲ or ▼. If value is set to:

- “OFF” regeneration will be based solely on the day override set (see Installer Display/Settings Step 5I); or
 - a number, regeneration initiation will be based off the value specified.
- See Setting Options Table for more detail. Press REGEN to return to previous step.

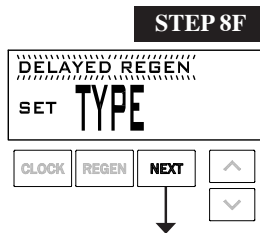

Step 8F – Set Regeneration Time Options using ▲ or ▼. If “OFF” was selected in Step 7F, this screen will not appear.

If value is set to:

- “DELAYED REGEN” means regeneration will occur at the preset time;
 - “IMMEDIATE REGEN” means regeneration will occur immediately when the volume capacity reaches 0 (zero); or
 - “BOTH” means regeneration will occur at one of the following:
 - the preset time when the volume capacity falls below the reserve or the specified number of days between regenerations is reached whichever comes first; or
 - immediately after 10 minutes of no water usage when the volume capacity reaches 0 (zero).
 - “DELAYED REGEN is the default if Step 4CS is set to VALVE A or VALVE B, and “BOTH” will not be available.
 - “IMMEDIATE REGEN” is the default if Step 2CS is set to 1.0T, and “BOTH” is not available.
- This step will not appear if Step 8S is set to OFF or Step 4CS is set to “SYSTEM CONTROLLER”. See Setting Options Table for more detail. Press NEXT to go to Step 9F.



Step 9F – Set Relay 1 operation using ▲ or ▼. The choices are:

- Set REGEN TIME: Relay activates after a set time at the beginning of a regeneration and then deactivates after a set period of time. The start of regeneration is defined as the first backwash cycle or Regenerant Draw UP (1” only) or DN, whichever comes first.
 - Set VOLUME: Relay activates after a set volume has been used while in service, then deactivates after the meter stops registering flow and the set time period has expired.
 - Set REGEN VOLUME: Relay activates after a set volume has been used while in service or during regeneration, then deactivates after the meter stops registering flow and the set time period has expired.
 - Set OFF: If set to Off, Steps 10F and 11F will not be shown.
- Press NEXT to go to Step 10F. Press REGEN to return to previous step.

STEP 10F

RELAY 1 SETPOINT	
SET	10 MIN
CLOCK	REGEN
NEXT	▲
	▼

Step 10F – Set Relay 1 SETPOINT Time or Volume using ▲ or ▼. The choices are:

- Relay Actuation Time: After the start of a regeneration the amount of time that should pass prior to activating the relay. The start of regeneration is defined as the first backwash cycle or Regenerant Draw UP or DN, whichever comes first. Ranges from 0 to 500 minutes.
- Relay Actuation Volume: Relay activates after a set number of liters have passed. Ranges from 1 to 200 liters.

Press NEXT to go to Step 11F. Press REGEN to return to previous step.

STEP 11F

RELAY 1 DURATION	
SET	5:00 MIN
CLOCK	REGEN
NEXT	▲
	▼

Step 11F: Set Relay DURATION TIME using ▲ or ▼.

- If TIME is selected in Step 9F, the relay will deactivate after the time set has expired. Ranges from 0:01 to 500:00 minutes.
- If Volume or REGEN Volume is selected in Step 9F, the relay will deactivate after the time set has expired.

Press NEXT to go to Step 12F. Press REGEN to return to previous step.

STEP 12F

VOLUME RELAY 2	
SET	RELAY 2
CLOCK	REGEN
NEXT	▲
	▼

Step 12F: Set Relay 2 operation using ▲ or ▼. Set Relay 1 operation using ▲ or ▼. The choices are:

- Set TIME: Relay activates after a set time at the beginning of a regeneration and then deactivates after a set period of time. The start of regeneration is defined as the first backwash cycle or Regenerant Draw UP or DN, whichever comes first.
- Set Volume: Relay activates after a set number of liters have been used while in service and then deactivates after a set period of time or after the meter stops registering flow, whichever comes first.
- Set REGEN Volume: Relay activates after a set number of liters have been used while in service or during regeneration and then deactivates after a set period of time or after the meter stops registering flow, whichever comes first.
- ERROR MONITOR: Relay closes whenever the valve enters error mode, and immediately deactivates when error mode is exited.
- Set OFF: If set to Off, Steps 10F and 11F will not be shown.

Press NEXT to go to Step 10F. Press REGEN to return to previous step.

• If set to OFF or ERROR MONITOR, Steps 13F and 14F will not be shown.

Press NEXT to go to Step 13F. Press REGEN to return to previous step.

STEP 13F

RELAY 2 SETPOINT	
SET	20 L
CLOCK	REGEN
NEXT	▲
	▼

Step 13F: Set Relay 2 SETPOINT Time or Volume using ▲ or ▼. The choices are the same as Step 10F.

Press NEXT to go to Step 14F. Press REGEN to return to previous step.

STEP 14F

RELAY 2 DURATION	
SET	5:00 MIN
CLOCK	REGEN
NEXT	▲
	▼

Step 14F: Set Relay DURATION TIME using ▲ or ▼.

- If TIME is selected in Step 12F the relay will deactivate after the time set has expired.
- If Volume or REGEN Volume is selected in Step 12F the relay will deactivate after the time set has expired or after the meter stops registering flow, whichever comes first.

Press NEXT to go to Step 15F. Press REGEN to return to previous step.

STEP 15F

SERVICE ALARM	
SET	OFF
CLOCK	REGEN
NEXT	▲
	▼

Step 15F: Set Service Alarm using ▲ or ▼. The choices are Time, m³, BOTH or OFF. Selecting OFF disables this feature. If OFF is selected press NEXT to exit OEM System Setup. If TIME, m³ or BOTH is selected press NEXT to select the TIME and/or m³ values. Press REGEN to return to previous step.

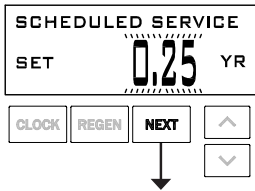
STEP 16F

Step 16F: Set the desired interval between service alarms, either in m³ or fractions of a year. Press NEXT to go to Step 17F. Press REGEN to return to previous step.

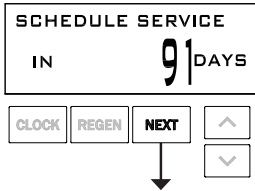
STEP 17F

Step 17F: Status Display. Time or Volume remaining until Service Alarm generation. To reset duration time or volume, press and hold ▲ or ▼ for about 3 seconds. Press NEXT to exit OEM Filter System Setup or go to the next step if BOTH was selected in Step 15F. Press REGEN to return to the previous step.

NOTE: To clear the Service Call reminder, press ▲ and ▼ simultaneously while the reminder screen is displayed.

**RETURN TO
NORMAL MODE**

Installer Display Settings

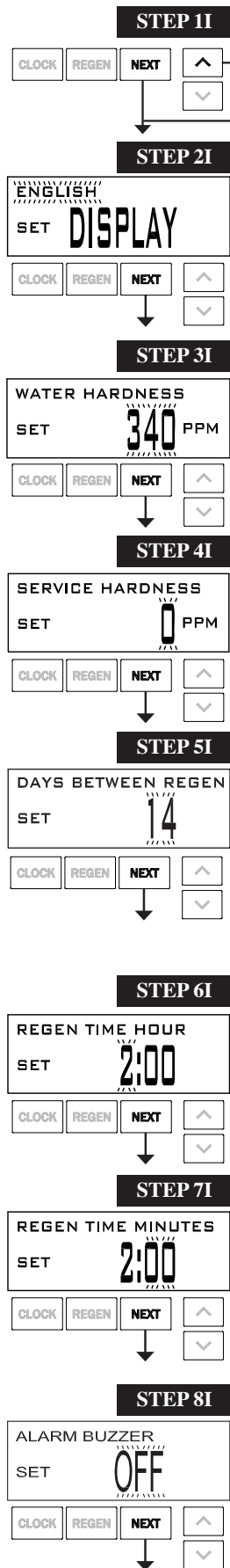

STEP 1I - Press NEXT and ▲ simultaneously for 3 seconds.

STEP 2I – Set Display Language. Select between English, French, Dutch or German. Press NEXT to go to Step 3I. Press REGEN to exit Installer Display Settings.

STEP 3I – Hardness: Set the amount of influent hardness using ▼ or ▲. See Table. This display will not appear if “FILTERING” is selected in Step 2F OR if “OFF” or a number was selected in Step 8S. Press NEXT to go to step 4I. Press REGEN to exit Installer Display Settings.

Setting	Limits	Default
PPM	1-2500	340
°fH	1-250	34
°dH	1-150	18

STEP 4I – Service Water Hardness - If a mixing valve is installed in the valve, service hardness needs to be set. Setting range is always less than the setting in Step 3I. This screen will not be displayed when valve is set as a Filter, 1.5 or 2.0 valve type, or if Auto is not selected in Step 8S. Press NEXT to go to Step 5I. Press REGEN to return to previous step.

STEP 5I – Day Override: When volume capacity is set to “OFF”, sets the number of days between regenerations. When volume capacity is set to AUTO or to a number, sets the maximum number of days between regenerations. If value set to “OFF”, regeneration initiation is based solely on volume used. If value is set as a number (allowable range from 1 to 28) a regeneration initiation will be called for on that day even if sufficient volume of water was not used to call for a regeneration. Set Day Override using ▼ or ▲:

- number of days between regeneration (1 to 28); or
- “OFF”.

See Setting Options Table for more detail on setup. Press NEXT to go to Step 6I. Press REGEN to return to previous step.

STEP 6I – Next Regeneration Time (hour): Set the hour of day for regeneration using ▼ or ▲. The default time is 2:00. This display will show not to be viewed if “IMMEDIATE REGEN” is selected in Set Regeneration Time Option in OEM Softener System Setup Step 9S or OEM Filter System Setup Step 8F. Press NEXT to go to Step 7I. Press REGEN to return to previous step.

STEP 7I – Next Regeneration Time (minutes): Set the minutes of day for regeneration using ▼ or ▲. This display will not be shown if “IMMEDIATE REGEN” is selected in Set Regeneration Time Option in OEM Softener System Setup Step 9S or OEM Filter System Setup Step 8F. Press NEXT to go to Step 8I. Press REGEN to return to previous step.

STEP 8I – Alarm Buzzer. Select ON or OFF to activate an audio alarm whenever a valve or MAV error occurs, or when a Service Alarm is generated. Press NEXT to exit Installer Display Settings.

RETURN TO NORMAL MODE

User Display Settings

When the system is operating, several displays may be shown. Pressing NEXT will alternate between the displays. One of the displays is the current time of day. CAPACITY REMAINING is the cubic meters that will be treated before the system goes through a regeneration cycle. Pressing ▼ while in the Capacity Remaining display will decrease the capacity remaining in .01 m³ increments and will also increase the volume used impacting the recorded values in Diagnostics Steps 3D, 4D and Valve History, Step 5VH. DAYS TO A REGEN is the number of days left before the system goes through a regeneration cycle. Pressing ▼ while in this screen will temporarily or decrease the displayed value by 1 day. Another display shows the current treated water flow rate through the system. Contact information will be displayed if it was edited. To clear the Service Call reminder, press ▲ and ▼ simultaneously while the reminder screen is displayed. Either DP or HOLD will be displayed if the dP switch is closed. If the system has called for a regeneration that will occur at the pre-set time of regeneration, the words REGEN TODAY will alternate with the header on the display. If a water meter is installed, the flow indicator appears on the display when water is being treated (i.e. water is flowing through the system).

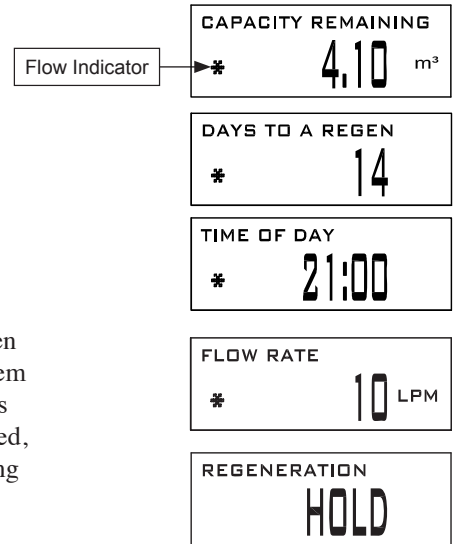

REGEN PENDING will be displayed in Alternator Systems whenever a unit is waiting to initiate the first cycle step of regeneration.

STAND BY will be displayed in Alternator Systems when a valve is in Standby state.

A scrolling DELAYED RINSE+FILL PENDING message will be displayed whenever a zero-capacity tank has transferred to an off-line state and is currently waiting to initiate the second portion of a regeneration cycle. Viewed only when Delayed Rinse and Fill is set to ON.

LOW BATTERY is shown when the 3V lithium battery is less than 2.85V. This screen alternates with the normal display.



Regeneration Mode

Typically a system is set to regenerate at a time of low water usage. An example of a time with low water usage is when a household is asleep. If there is a demand for water when the system is regenerating, untreated water will be used.



When the system begins to regenerate, the display will change to include information about the step of the regeneration process and the time remaining for that step to be completed. The system runs through the steps automatically and will reset itself to provide treated water when the regeneration has been completed.

Manual Regeneration

Sometimes there is a need to regenerate the system sooner than when the system calls for it, usually referred to as manual regeneration. There may be a period of heavy water usage because of guests or a heavy laundry day.

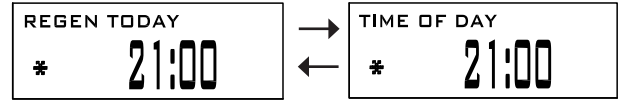

To initiate a manual regeneration at the preset delayed regeneration time, when the regeneration time option is set to "DELAYED REGEN" or "BOTH", press and release "REGEN". The words "REGEN TODAY" will periodically be shown on the display to indicate that the system will regenerate at the preset delayed regeneration time. If you pressed the "REGEN" button in error, pressing the button again will cancel the request. Note: If the regeneration time option is set to "IMMEDIATE REGEN" there is no set delayed regeneration time so "REGEN TODAY" will not activate if "REGEN" button is pressed.

To initiate a manual regeneration immediately, press and hold the "REGEN" button for three seconds. The system will begin to regenerate immediately. The request cannot be cancelled.

Note: For softeners, if brine tank does not contain salt, fill with salt and wait at least two hours before regenerating.

Set Time of Day

The user can also set the time of day. Time of day should only need to be set if the battery has been depleted because of extended power outages or when daylight saving time begins or ends. If an extended power outage occurs, the time of day will flash on and off which indicates the time of day should be reset. The non rechargeable battery should also be replaced.

STEP 1U

STEP 1U – Press CLOCK.



STEP 2U

STEP 2U - Current Time (hour): Set the hour of the day using ▼ or ▲. Press NEXT to go to Step 3U.

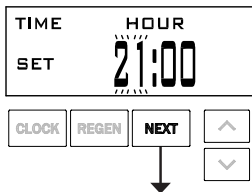

STEP 3U

STEP 3U - Current Time (minutes): Set the minutes of the day using ▼ or ▲. Press NEXT to exit Set Time of Day. Press REGEN to return to previous step.

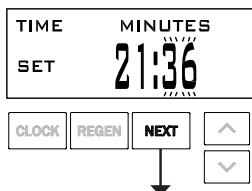

RETURN TO NORMAL MODE

Power Loss

If the power goes out the system will keep time until the battery is depleted. If an extended power outage occurs, the time of day will flash on and off which indicates the time of day should be reset and the non rechargeable battery replaced. The system will remember the rest.

Error Message

If the word "ERROR" and a number are displayed contact the OEM for help. This indicates that the valve was not able to function properly. If the number and banner text in the Contact Screens has been edited, the two displays below will alternate.

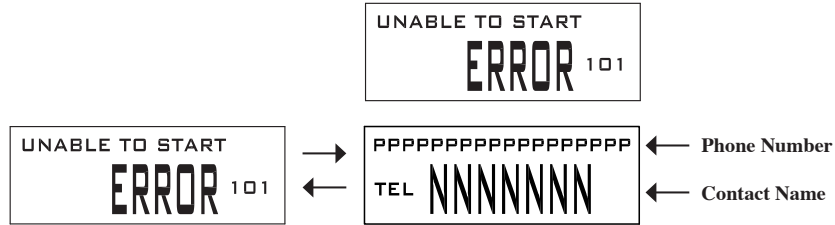

Diagnostics

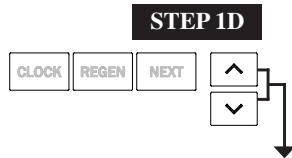

STEP 1D – Press ▲ and ▼ simultaneously for three seconds. If screen in step 2D does not appear in 5 seconds the lock on the valve is activated. To unlock press ▼, NEXT, ▲, and CLOCK in sequence, then press ▲ and ▼ simultaneously for 3 seconds.

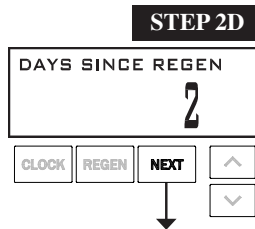

STEP 2D – Days, since last regeneration: This display shows the days since the last regeneration occurred. Press NEXT to go to Step 3D. Press REGEN to exit Diagnostics.

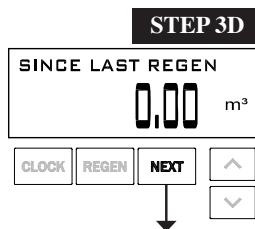

STEP 3D – Volume, since last regeneration: This display shows the volume of water that has been treated since the last regeneration. This display will equal zero if a water meter is not installed. Press NEXT to go to Step 4D. Press REGEN to return to previous step.

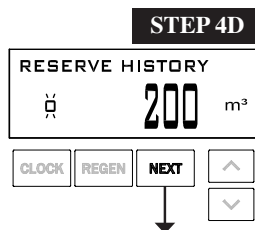

STEP 4D – Reserve History Volume used for last 7 days: If the valve is set up as a softener, a meter is installed and Set Volume Capacity is set to “Auto,” this display shows 0 day (for today) and the reserve capacity. Pressing ▲ will show day 1 (which would be yesterday) and the reserve capacity used. Pressing ▲ again will show day 2 (the day before yesterday) and the reserve capacity. Keep pressing ▲ to show the capacity for days 3, 4, 5 and 6. ▼ can be pressed to move backwards in the day series. This screen is not displayed if filter, time clock, meter immediate, alternator or volume override regeneration is selected. Press NEXT at any time to go to Step 5D. Press REGEN to return to previous step.

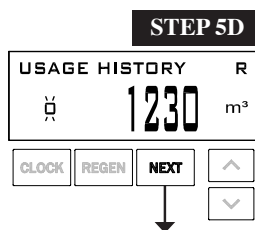

STEP 5D - Volume, 63-day usage history: This display shows day 0 (for today), day 1 (for yesterday), etc., and the volume of water treated that day. Press ▲ to show the volume of water treated for the last 63 days. If a regeneration occurred on the day the letter “R” will also be displayed. This display will show dashes if a water meter is not installed. Press NEXT at any time to go to Step 6D. Press REGEN to return to previous step.

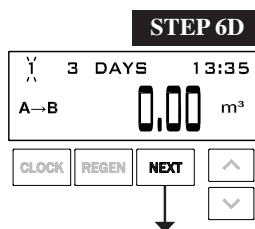

STEP 6D - Tank Transfer History. Only displayed when 1.0T is selected in Step 2CS. Use ▲ or ▼ to scroll through the last 10 tank transfers. “1”= transfer number – 10 transfers maximum. “A” = tank transferring. “3 DAYS” = days ago of transfer – 99 days maximum. “0.00 m³” = cubic meters used at time of tank transfer. “13:35” = time of transfer.

Press NEXT at any time to go to Step 7D. Press REGEN to return to previous step.

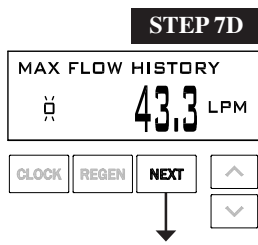

STEP 7D – Flow rate, maximum last seven days: Use ▲ or ▼ to display the maximum flow rate in liters per minute that occurred in each of the last seven days. This display will equal zero if a water meter is not installed. Press NEXT to go to Step 8D. Press REGEN to return to previous step.

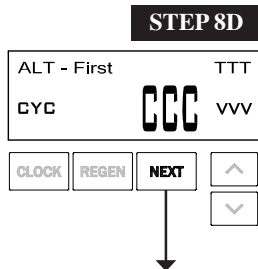

STEP 8D – MAV Drive History: Displays the drive time histories of all active MAV drives. Use ▲ or ▼ to review the history of all active MAV outputs. TTT – measured MAV drive time; VVV – measured MAV drive voltage; CCC – total number of drives (in or out); “-” indicates piston drive into MAV; “+” indicates piston drive out of MAV. **NOTE: After a drive error occurs or a MAV is replaced, it is recommended that the diagnostics screen for that MAV be cleared. That is done by selecting the + or – screen for that MAV. Press and hold ▲ and ▼ for about 3 seconds. Failure to do this may result in inconsistent MAV operation.** Press NEXT to exit Diagnostics. Press REGEN to return to previous step.

RETURN TO NORMAL MODE

When desired, all programming and information in Diagnostics may be reset to defaults when the valve is installed in a new location. To reset, press NEXT and ▼ simultaneously to go to the Softening/Filtering screen. Press ▲ and ▼ simultaneously to reset programming and diagnostic values. Screen will return to User Display.

Valve History

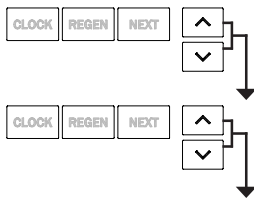
STEP 1VH

STEP 1VH – Press ▲ or ▼ simultaneously for three seconds and release. Then press ▲ and ▼ simultaneously and release. If screen in step 2VH does not appear in 5 seconds the lock on the valve is activated. To unlock press ▼, NEXT, ▲, and CLOCK in sequence, then press ▲ and ▼ simultaneously for 3 seconds and release. Then press ▲ and ▼ simultaneously and release.

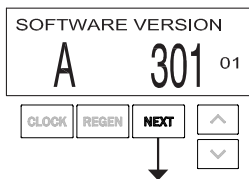
STEP 2VH

STEP 2VH – Software version: Displays current software version. Press NEXT to go to Step 3VH. Press REGEN to exit Valve History.

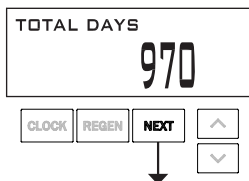
STEP 3VH

STEP 3VH⁴ – Days, total since start-up: This display shows the total days since startup. Press NEXT to go to Step 4VH. Press REGEN to return to previous step.

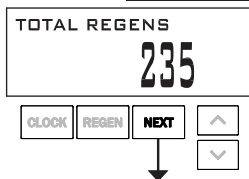
STEP 4VH

STEP 4VH – Regenerations, total number since start-up: This display shows the total number of regenerations that have occurred since startup. Press NEXT to go to Step 5VH. Press REGEN to return to previous step.

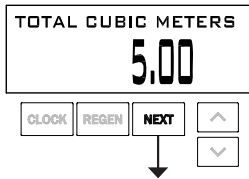
STEP 5VH

STEP 5VH – Volume, total used since start-up: This display shows the total cubic meters treated since startup. This display will equal zero if a water meter is not installed. Press NEXT to go to Step 6VH. Press REGEN to return to previous step.

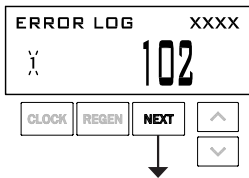
STEP 6VH

STEP 6VH – Error Log: This display shows a history of the last 10 errors generated by the control during operation. Press ▲ and ▼ to view each error recorded. Press NEXT to exit Valve History. Press REGEN to return to previous step. XXXX = Indicates the position of the drive at the time of stall detection.

RETURN TO NORMAL MODE

⁴ Values in steps 3VH through 6VH cannot be reset.

Revision History:

1/28/2020

PAGE 4:

4	V3650AR-02BOARD	WS1 THRU 2 AR PC BRD REPL	1
---	-----------------	---------------------------	---

New #4 - Board drawing

PAGE 7:

Removed "Cycle Options" table

Step 1CS: Added another button set

PAGE 8:

Set to VALVE A Connect the outlet plumbing of VALVE A valve to the MAV's A port and connect the MAV's two pin wire connector to the two pin connector labeled "MAV" on VALVE A

Moved under table: If set up for a filter, in Step 7F set Volume Capacity in m³...

PAGE 16:

New table

PAGE 21:

Step 2I: Set Display Language. Select between English, French, Dutch or German.

Step 4I: This screen will not be displayed when valve is set as a Filter, 1.5 or 2.0 valve type, or if Auto is not selected in Step 8S.

Step 7I: Press NEXT to go to Step 8I.

Added Step 8I

PAGE 22:

Added - LOW BATTERY is shown when the 3V lithium battery...

PAGE 27:

Step 2VH - New display screen

4/16/2020

PAGE 4:

Removed #7 - V3106-01 - table and drawing

Not Shown	V3186-06	WS1 POWER SUPPLY US 15VDC HOCP	1
	V3186AUS-05OD	WS1 POWER SUPPLY AUS 15VDC VI OUTDOOR	
	V3186EU-06	WS1 POWER SUPPLY EU 15VDC HOCP	
	V3186UK-06	WS1 POWER SUPPLY UK 15VDC HOCP	
	V3186-01	WS1 POWER CORD ONLY	