

Application

- Can be used to transfer clean water or other liquids similar to water in physical and chemical properties
- Suitable for industrial use and urban water supply, pressure boosting for high buildings and fire fighting, garden irrigation, long-distance water transfer, heating ventilation and air conditioning, circulation and pressure boosting for cold and hot water, and supporting equipment etc.

Pump

- Cast iron pump body and support under special anti-rust treatment
- AISI 304 shaft
- Max. liquid temperature: +60°C
- Max.suction: + 8 m

Motor

- Low noise&Long life bearing
- Motor with copper winding
- Built-in thermal protector for single phase motor
- Insulation class: F
- Enclosures class: IPX4
- Max. ambient temperature: +50°C
- IE 2 motor (Three phase, power ≥ 0.75kW)

Identification Codes

2 A C m 150 (H)

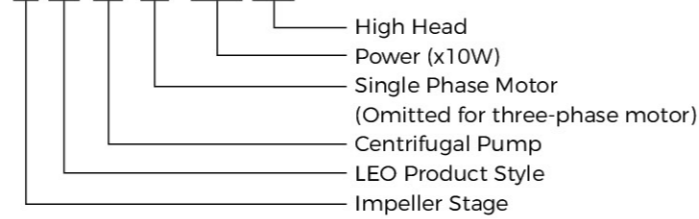

Technical Data

Model		Power		Q(m³/h)																			
Single Phase	Three Phase	kW	HP	0	1.2	1.8	2.4	3	3.6	4.2	4.8	5.4	6	6.6	7.2	8.4	9.6	10.8	12	15			
				Q(l/min)	0	20	30	40	50	60	70	80	90	100	110	120	140	160	180	220	250		
2ACm75	2AC75	0.75	1	H (m)	45	42.5	40	37	33.5	28.5	23	15	-	-	-	-	-	-	-	-	-		
2ACm110	2AC110	1.1	1.5		47	46	45	44	43	41.5	40	38	35.5	33	30.5	28	22	-	-	-	-	-	
2ACm150	2AC150	1.5	2		57.5	55.5	54.5	53.5	52	50.5	49	47	44.5	41.5	38.5	35	28	20	-	-	-	-	
2ACm150H	2AC150H	1.5	2		63.5	60.5	58.5	56.5	54	51.5	48.5	45	41	37.5	33.5	29	-	-	-	-	-	-	
-	2AC220	2.2	3		65	63	62	61	59.5	58	56	54	51.5	49	46	43	36	28.5	20.5	-	-	-	
2ACm300H	-	3	4		65	-	-	62	61	60	59	58	56.5	55	53.5	52.5	48.5	44.5	40	35	21	-	
-	2AC300H	3	4		70	-	-	67	66	65	64	63	62	61	59.5	59	55.5	52	49	45	33	-	
-	2AC400H	4	5.5		82	-	-	79.5	78.5	77.5	76.5	75.5	74.5	73.5	72	71	67.5	64.5	61	57	45.5	-	

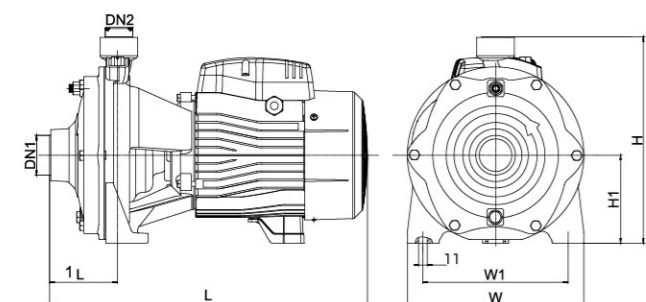

Dimension

Model	DN1	DN2	L (mm)	L1 (mm)	H (mm)	H1 (mm)	W (mm)	W1 (mm)
2AC(m)75	1 1/4"	1"	337	72	231	100	181	145
2AC(m)110	379		78	225	92.5	200	162	
2AC(m)150	402		88	263	112	225	185	
2AC(m)150H	1 1/2"	1 1/4"	481	99	311	132	281	234
2AC220								
2ACm300H								
2AC300H								
2AC400H								

Hydraulic Performance Curves

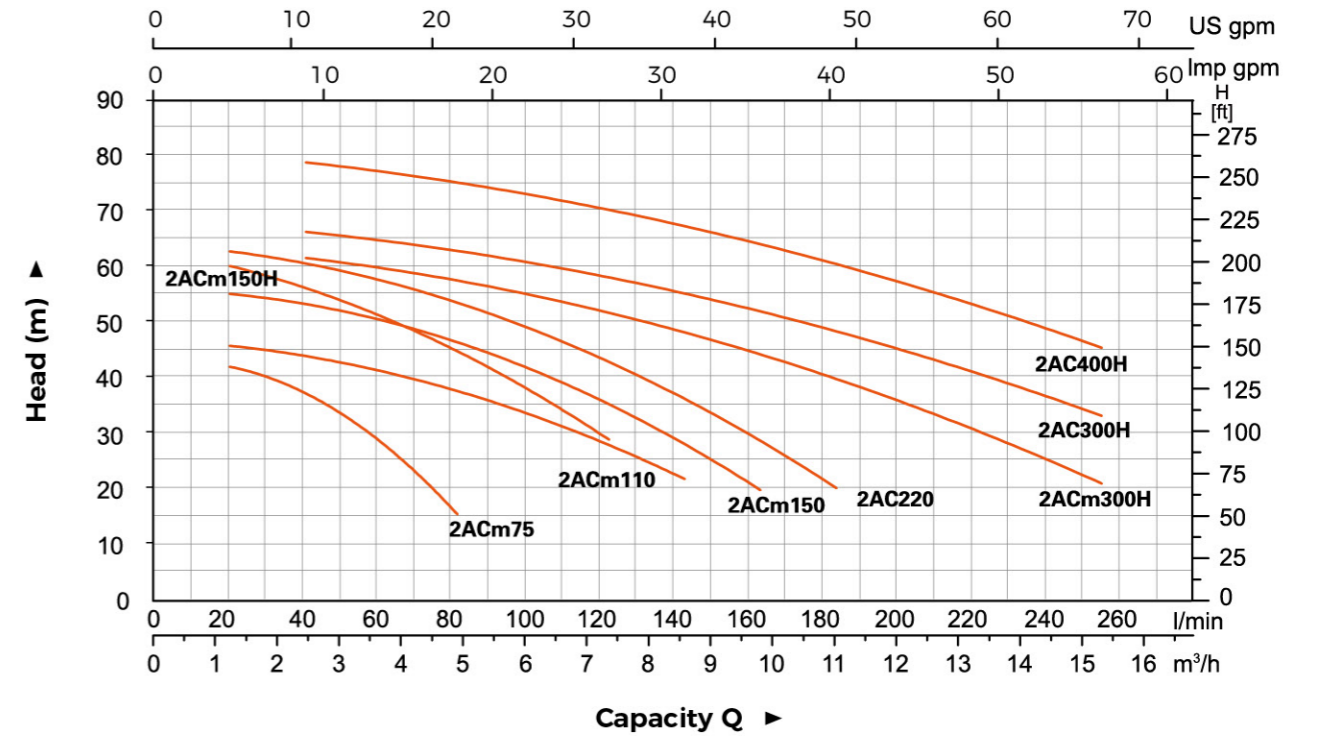

Material Table

No.	Part	Material	No.	Part	Material
1	Pump body	HT200	11	Terminal board	
2	Impeller	HPb59-1	12	Stator	
3	Water baffle	HT200	13	Rotor	
4	Mechanical seal		14	Deep groove ball bearing	
5	Bracket	HT200			
6	Fan cover	PP			
7	Fan	PP-GF10			
8	End plate	ADC12			
9	Cover box	PP-GF20			
10	Capacitor				

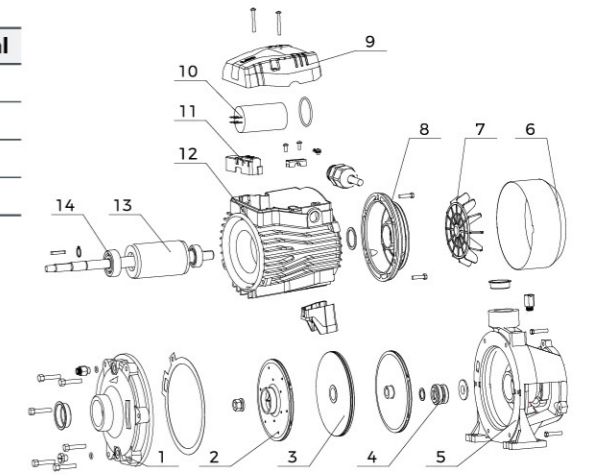

Package Information

Model	CW (Kgs)	L (mm)	W (mm)	H (mm)	Quantity (PCS/20'TEU)
2AC(m)75	16.8	385	215	270	1190
2AC(m)110	22	430	235	275	833
2AC(m)150	26.4	445	255	300	636
2AC(m)150H	27	445	255	300	636
2AC220	27.5	445	255	300	629
2ACm300H	49	542	330	360	337
2AC300H	48.6	542	330	360	340
2AC400H	48.5	542	330	360	346

